

# ecosystem™ Over 15 Patents Pending

The energy efficient Gemini Twin™ fully integrates into the Ecosystem™ product range and is compatible with any type of filtration system. See [www.poolrite.tv](http://www.poolrite.tv) for product integration.



## Super Efficient Multi-Speed Pump

The Poolrite Gemini Twin™ pump is Ecosystem™ enabled to significantly reduce energy consumption and carbon emissions. Change speed from HIGH to LOW on each power up. Changing speed is simple and easy to do as required via the remote control.

## Another Safe-T-Lok Product

The pump is Safe-T-Lok™ enabled featuring an emergency stop button on the remote control.

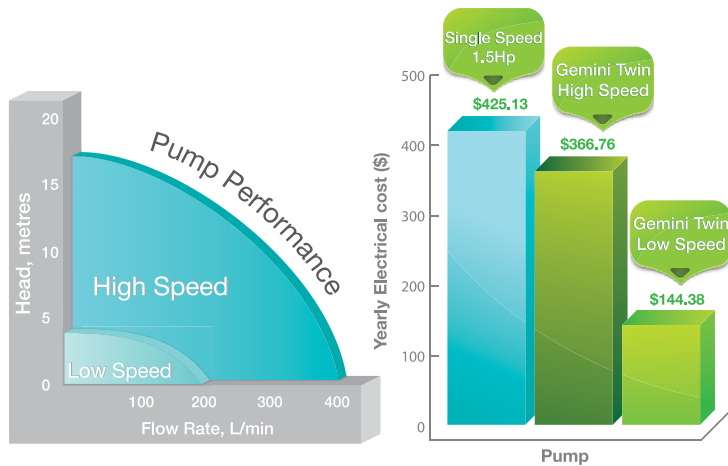

\*Annual pump operating cost is based on turning over an average size pool of 50,000L twice per day at \$.20 per kWh.

## Specifications & Dimensions

Output (Hp)	Output (W)	Pipe Size	Carton Weight	Motor
0.15 – 1.20 Hp	110 – 900 W	40-50mm	17KG	AC

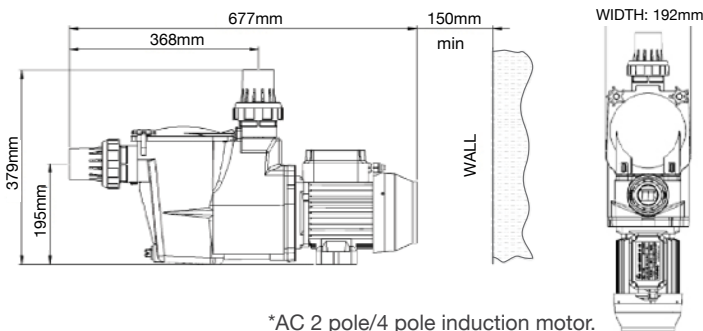

\*AC 2 pole/4 pole induction motor.

## Features

- ✓ For use on any pool system.
- ✓ Highly efficient energy saving pump reduces operating costs and carbon emissions.
- ✓ Tried & tested AC induction motor technology.
- ✓ Low noise pump to operate during off-peak hours.
- ✓ Remote control included as standard, operates all pump functions up to a range of 25m.
- ✓ Safe-T-Lok™ enabled remote control features a stop button in case of entrapment emergency.
- ✓ To unlock more functionality consider purchasing a Radio Net™ Outdoor Computer.

## Unique operating modes:

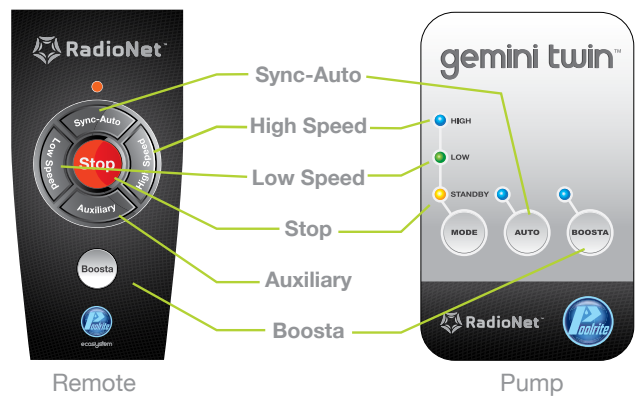

**AUTO mode:** Automatically changes speed between HIGH and LOW on each power-up to enhance effectiveness of pool cleaning equipment.

**SYNC mode:** Changes the sequence of HIGH & LOW speed.

**BOOSTA mode:** Runs pump at high speed for 30 minutes for rapid cleaning.

## Super Quiet Operation - 55dBA\*\*

Through intelligent noise suppression design with thicker housing material and efficient impellor design, pump noise is almost eliminated. Ideal for use during off-peak times.

\*\*55dBA at 1.5m from pump

## Warranty

- ✓ 10 Year main pump housing
- ✓ 1 Year on all electronics
- ✓ 2 Year motor, mechanical seal and all other components



Poolrite products are manufactured to the highest possible standard using the most current technologies, so you can enjoy the benefits year after year.



## Rainbow Pool Products

PO Box 2388, Mansfield Qld 4122  
 Telephone STD 61-7-3849 5385  
 Facsimile STD 61-7-3849 5384  
 Email: [info@rainbowpoolproducts.com.au](mailto:info@rainbowpoolproducts.com.au)  
 Web: [www.rainbowpoolproducts.com.au](http://www.rainbowpoolproducts.com.au)