



Quality Pool & Spa Products

VICTORIA PUMP



Code

Description

Victoria Pump

2 Year Warranty

20599-0860	V 0.75	0.75HP	Single Phase
20601-0860	V 1.00	1.00HP	Single Phase
20603-0860	V 1.50	1.50HP	Single Phase
20605-0860	V 2.00	2.00HP	Single Phase
20607-0860	V 3.00	3.00HP	Single Phase

SPECIFICATIONS

Victoria Pump

Description:

Robust design with new generation easy to handle lid lock nut and unique lid handle. Low noise levels due to rubber supports. IP-55 motor protection. Large capacity strainer basket. Flow rates given at 10 head.

Ordering:

Please specify product number when ordering.

Warranty Guide:

Limited two (2) year warranty on all components.

Refer to instructions and website for full warranty details

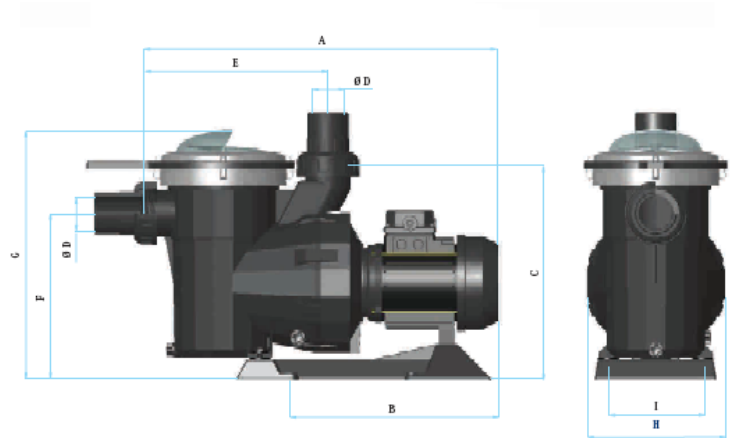

Code	HP	A	B	C	Ø D	E	F	G	H	I
20599	3/4	562	335	323	40/50	281	243	366	210	144.5
20601	1	562	335	323	40/50	281	243	366	210	144.5
20603	1,5	592	366	323	40/50	281	243	366	210	144.5
20605	2	592	366	323	40/50	281	243	366	210	144.5
20607	3	592	366	323	40/50	281	243	366	210	144.5

Model	Voltage	Phase	Output	Full Load
V 0.75	240	Single	600	3.2
V 1.00	240	Single	750	4.3
V 1.50	240	Single	1100	6.6
V 2.00	240	Single	1500	7.5
V 3.00	415	Three	2100	2.2/ph

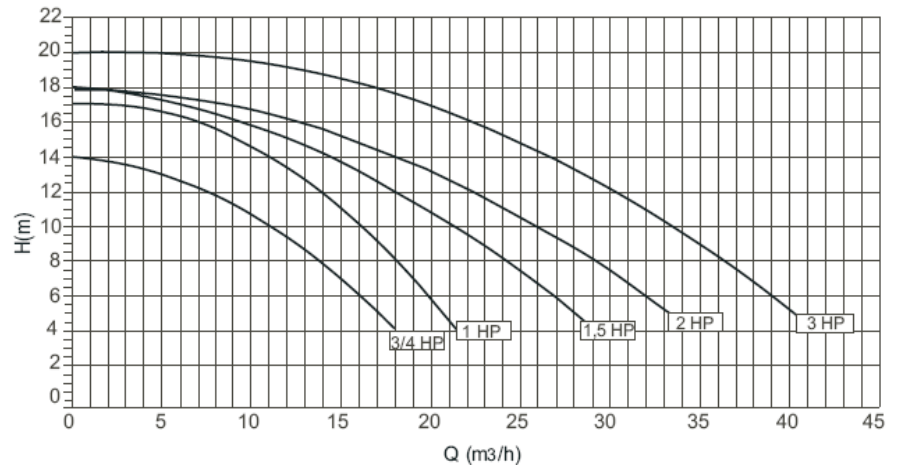

Product Code	Flow Rate @ 10 m/h	Max Noise Level @ 1 mtr
--------------	--------------------	-------------------------

Victoria Pump - 0.75 HP
 Victoria Pump - 1.00 HP
 Victoria Pump - 1.50 HP
 Victoria Pump - 2.00 HP
 Victoria Pump - 3.00 HP

20599-0860	185 lpm	57 dBA
20601-0860	270 lpm	57 dBA
20603-0860	360 lpm	58 dBA
20605-0860	435 lpm	58 dBA
20607-0860	570 lpm	60 dBA