

Key	Description	Product Code
1	Chlorinator Loom Assembly	70300
2	Power Cord	350025
3	Fuse VX 7 PCB	70352
4	Transformer VX 6 & 7	70304
	Transformer VX 9	70305
	Transformer VX 11	70306
	Transformer VX 13	70307
5	VX PCB Power Module with time clock	70297
	VX PCB Power Module no time clock	70327
6	Battery VX Chlorinator	70313
7	Ribbon Cable VX Chlorinator	non
8	VX PCB User Control	70298
9	Cell Assembly Complete - VX 6	10989
	Cell Assembly Complete - VX 7	10906
	Cell Assembly Complete - VX 9	10907
	Cell Assembly Complete - VX 11	10908
	Cell Assembly Complete - VX 13	10988
	Cell Assembly Complete - VX 6 - No Housing or lock nut	10989A
	Cell Assembly Complete - VX 7 - No Housing or lock nut	10906A
	Cell Assembly Complete - VX 9 - No Housing or lock nut	10907A
	Cell Assembly Complete - VX 11 - No Housing or lock nut	10908A
	Cell Assembly Complete - VX 13 - No Housing or lock nut	10988A
10	"O" Ring 50mm union	70003
11	Tail 40mm	950918
	Tail 50mm	950920
12	Locknut Union 50mm	950919
13	Chlorinator Facia Label - Timer	LABEL76

Salt Chlorinator V2 & V3

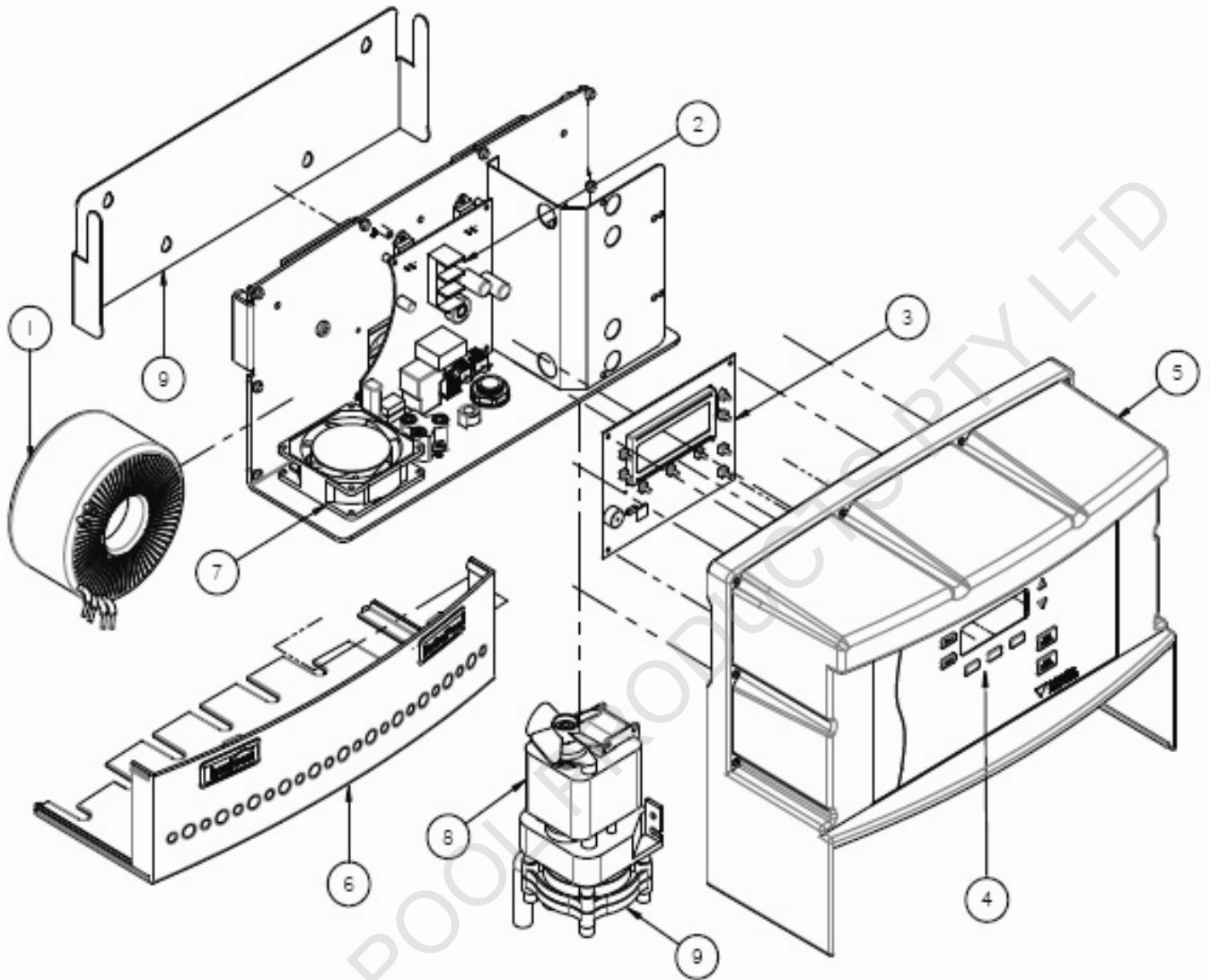

RAINBOW POOL SUPPLY LTD

Key	Description	Product Code
1	Transformer VX 6 & 7	70304
	Transformer VX 9	70305
	Transformer VX 11	70306
	Transformer VX 13	70307
2	VX PCB Power Module with time clock V2 (Pre Feb 2008)	70297
	VX PCB Power Module no time clock V2 (Pre Feb 2008)	70327
2	VX PCB Power Module with time clock V3 (Post Feb 2008)	70382
	VX PCB Power Module no time clock V3 (Post Feb 2008)	70383
3	VX PCB User Control including Ribbon Cable	70298
4	Facia Label V2 Timer - Pre Feb 2008	LABEL79
	Facia Label V2 No Timer - Pre Feb 2008	LABEL75
	Facia Label V3 Timer - Post Feb 2008 (Backwash)	LABEL153
	Facia Label V3 No Timer - Post Feb 2008 (Backwash)	LABEL154
5	Enclosure - Beige	10990
6	Enclosure Front - Beige	10991
7	Cooling Fan	76223
Not Shown	Chlorinator Loom Assembly	70300
Not Shown	Power Cord	350025
Not Shown	Fuse VX 7 PCB	70352
Not Shown	Battery VX Chlorinator	70313
Not Shown	Cell Assembly Complete - VX 6	10989
	Cell Assembly Complete - VX 7	10906
	Cell Assembly Complete - VX 9	10907
	Cell Assembly Complete - VX 11	10908
	Cell Assembly Complete - VX 13	10988
	Cell Assembly Complete - VX 6 - No Housing or lock nut	10989A
	Cell Assembly Complete - VX 7 - No Housing or lock nut	10906A
	Cell Assembly Complete - VX 9 - No Housing or lock nut	10907A
	Cell Assembly Complete - VX 11 - No Housing or lock nut	10908A
	Cell Assembly Complete - VX 13 - No Housing or lock nut	10988A
Not Shown	"O" Ring 50mm union	70003
Not Shown	Tail 40mm	950918
Not Shown	Tail 50mm	950920
Not Shown	Locknut Union 50mm	950919