

SUPER QUIET

DAVEY

ProMaster®

VSD200

## INNOVATIVE POOL PUMP

### APPLICATION

Ideal for pool filtration, in-floor pool cleaning systems, connection to external pool controllers, heat pumps and gas heaters. Suitable for pools from up to 110,000 litres.



residential

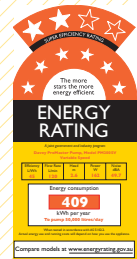

### HIGH EFFICIENCY, SUPER QUIET, WATER COOLED DESIGN

- > **Super Quiet** – Designed with a unique water-cooled motor which captures noise and vibrations, allowing super-quiet operation, rated down to 50 dBA. Your neighbours won't even know it's there.
- > **Fully Variable Speed Control** – The ProMaster offers the pool owner and operator total control over the speed at which the pump needs to operate, from 1,500rpm to 3,600rpm
- > **Energy Efficiency** – 8 Star energy rating offering up to 70% lower energy use than a traditional fixed speed 1hp pump\*
- > **Backwash Function** – ProMaster is designed with a selectable backwash cycle that runs the pump for 2 minutes at 3,800rpm before shutting down. It provides for safe, reliable and easy operation of the pump when backwashing your media filter.
- > **Dependable** – ProMaster incorporates unique loss of prime protection to minimise pump damage if no water is available to the pump.
- > **Convenient** – By water cooling the motor, ProMaster does not require air ventilation, and gives installers more flexibility with pump positioning
  - Easy to install set and operate, no complicated digital push button controls
  - Automatic restart technology
  - Large 4.5 litre leaf basket for long intervals between cleaning
  - Over temperature derating, pump will automatically slow down in high ambient temperatures
- > **Double insulated to water circuit** – provided with an Equipotential Bonding Point for AS/NZ 3000 wiring standards

\*Running your pump at low speed uses less energy to turnover the same amount of pool water.



Depend on Davey

**DAVEY**

# ProMaster

## VSD200 Pool Pump

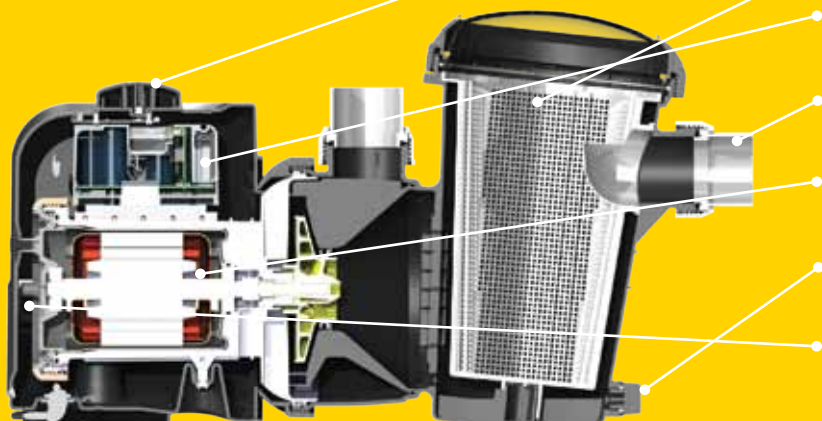

- Variable Frequency Drive** with selectable speed dial from 1500rpm to 3600rpm (Backwash mode at 3800rpm)
- Large Leaf Basket** with easy to remove, clear lid
- Loss of prime protection** to protect the pump when there is no water inside the pump
- Quality ABS quick coupling barrel unions** for simple installation
- High performance water cooled motor** for super quiet, efficient use all year round
- Drain plug** enables quick draining of the casing for easy removal and maintenance
- Double insulated to water circuit** with Equipotential Bonding Point

### ELECTRICAL DATA

Voltage (V)	240
Supply frequency (Hz)	50
Motor input power (W/hp)	116W/0.16hp @ Dial 1 488W/0.65hp @ Dial 5 1,000W/1.34hp @ Dial 10 1316W/1.76hp @ Backwash
Motor speed (rpm)	1,500 to 3,600
Backwash (rpm)	3800
Enclosure class (IP)	45
Insulation class	F
Power lead length	3m
Approval No.	SGS-150025

### HYDRAULIC PERFORMANCE

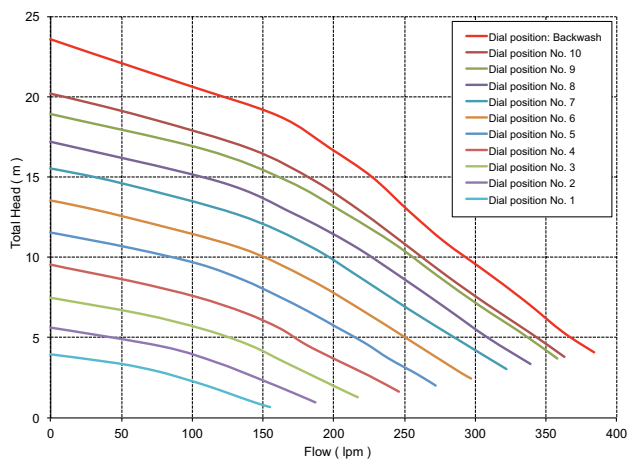

### OPERATING LIMITS

Max. water temperature	Max. ambient temperature	Noise level (AS 5102.2)
40°C	50°C	50 dBa (at Speed 1)

### DIMENSIONS (mm)

Model	A	B	C	D	E	F	G	H	I	Mounting Holes Diameter	Inlet/Outlet PVC	Net Weight (kg)
PM200SV	305	670	320	350	65	230	380	200	250	10	40/50	14

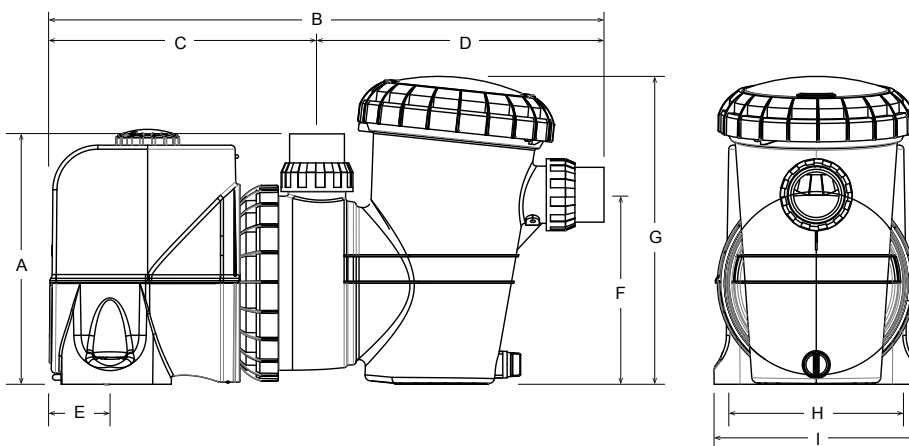

## Rainbow Pool Products

PO Box 2388, Mansfield Qld 4122

Telephone STD 61-7-3849 5385

Facsimile STD 61-7-3849 5384

Email: [info@rainbowpoolproducts.com.au](mailto:info@rainbowpoolproducts.com.au)

Web: [www.rainbowpoolproducts.com.au](http://www.rainbowpoolproducts.com.au)