



Quality Pool & Spa Products

MONARCH WHISPER SWIMMING POOL & SOLAR PUMP



Code	Description	Input		Output	
		hp	W	hp	W
M7510	W500	0.6	450	0.33	250
M7511	W750	0.9	650	0.5	370
M7512	W100	1.1	850	1	750

Guarantee - 3 years

Whisper™

Swimming Pool & Solar Pump

A compact pump for small to medium sized, above and below ground pools, and solar heating applications.



Features & Benefits

- Ideal for small pools, above ground pools and solar heating applications
- Compact dimensions – perfect for tight spaces
- Designed for durability and long life using corrosion resistant, UV stabilised materials
- High quality, reliable pump with low power usage
- Clear leaf basket lid designed for easy access and inspection of filtered debris
- Built in thermal overload protection, protects motor from low voltage or jammed pump
- Barrel union connections for easy pump installation

Guarantee – 3 years



monarchseries.com.au

Swimming Pool & Solar Pump

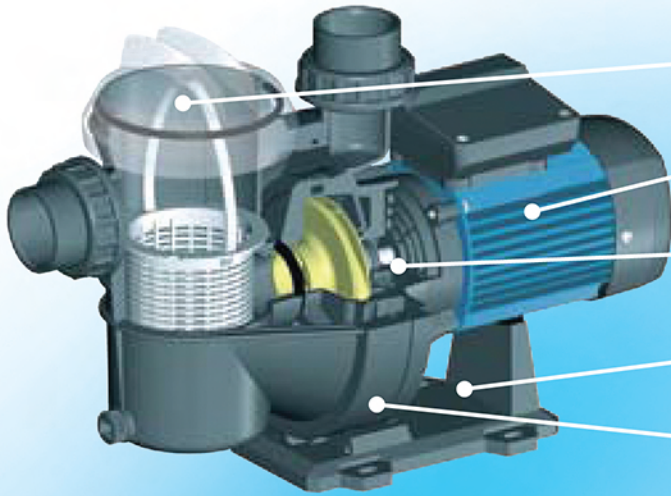

- Easy to remove, leaf basket cover for easy viewing and removal of leaves and debris
- Quiet and efficient motor
- Stainless steel motor shaft for corrosion resistance in salt water pools
- Pump body & base mount made from glass-filled polypropylene for corrosion resistance
- Compact and easy to install. Weighs 8.4kg or less.

ELECTRICAL DATA			
Model	500	750	1000
Voltage (V)	220-250		
Supply Frequency / Phase	50Hz / 1		
Run Current (A)	1.9	2.7	3.5
Motor Input Power (W)	450	650	850
Motor Output Power (W)	250	370	750
RPM	2900		
Enclosure Class (IP)	55		
Insulation Class	F		
Approval No.	W2442		

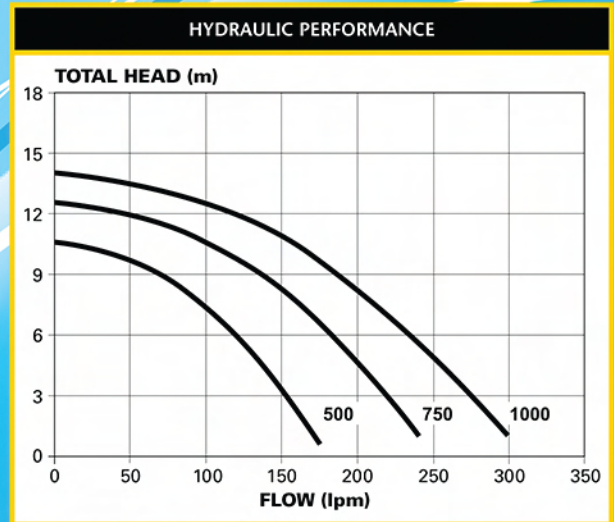

OPERATING LIMITS	
Water Temperature	Max 35°C
Ambient Temperature	Max 50°C

DIMENSIONS (mm)									
Model	A	B	C	D	E	F	G	H	Net Weight (Kg)
500									7.4
750	475	311.5	212	301	210	257	50	50	7.7
1000									8.4

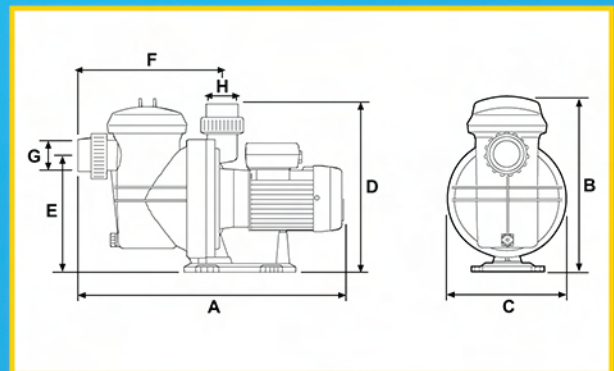

Datasheet Disclaimer:

All details in this leaflet are accurate at the time of printing. This literature is not a complete guide to product usage. Further information is available from your Monarch Series dealer, Davey Customer Service Centre and from the relevant product Installation & Operating Instructions. This datasheet must be read in conjunction with the relevant Installation & Operating Instructions and all applicable statutory requirements. Product specifications may change without notice. © Davey is a registered trademark of Davey Water Products Pty Ltd. © Davey Water Products Pty Ltd 2008.

Davey Water Products Pty Ltd

Member of the GUD Group
ABN 18 066 327 517

