

onga

SELF PRIMING JET PUMPS INSTALLATION INSTRUCTIONS

These instructions act as a guide only and do not cover every contingency. People not familiar with pumping equipment should seek advice from someone experienced with Onga equipment and pump installation.

Pump Protection: Warranty of these pumps is void unless they are housed correctly and protected from weather, floods, chemicals, dust, vermin insects etc. Housing used should be weather proof and well vented so that motor heat can escape. To obtain best possible performance pumps should be installed as close to water as possible. Depending on application they do not have to be bolted down. To protect pipe fittings, screw Aqua Pack on last.

Delivery Piping: Galvanised PVC or polythene pipe can be used. A short length of polythene pipe should be used either side of the pump so that noise is not transmitted into the house. For correct size of delivery pipe, refer to pipe friction tables. Pump should be connected through an isolating valve and pipe union so that water can be turned off and the system disconnected should the occasion arise.

Shallow Well Suction Pipe: Galvanised PVC or high grade polythene pipe can be used. A pipe friction table should be consulted to establish size of pipe. As it is important that there are no air leaks, pipe joints should be tightened correctly and jointing compound used. Self priming pumps should draw water through humps in the suction line but best results will be obtained if pipe rises evenly from water to pump. When pump is being used on flooded suction (from ground level tanks) a check valve should be used. Make sure it is installed in the correct direction. Water should be drawn 2 inches above the tank bottom so that sediment is not pumped through the system. On suction lifts, a foot valve MUST be used.

Deep Well Suction Pipe: The correct grade of polythene pipe should be used. Use a good joint sealant on all screwed pipe joints and tighten properly as air leaks will stop pump operating. When installing injector to pump, cut pipes so that when coupled they will lie straight side by side. Adequate heating of pipe ends makes them easy to push on. Tighten stainless steel hose clamps, two per fitting, so that pipes will not pull off.

Pressure Switch: All pressure switches are factory set to lowest pressure switch setting of the pump range. This suits most requirements. If high pressure injectors are used, reset pressure switch to catalogue recommended cut-in and cut-out pressures as per instructions contained in switch. In case of shallow well water pressure systems, it is an advantage to set top pressure switch setting about 5 lbs below maximum pump pressure when system is operating on maximum suction lift, i.e. dam, channel, river or when underground tanks are at their lowest level.

Electrical: All single phase systems are supplied with cord and plug for connection to 240 volt power outlets - 2 H.P. systems require a 15 amp plug. 480 volt single and 415 volt 3 phase systems must be equipped with a contactor incorporating thermal overload and wired by an electrician.

Hot Water Systems and Showers: Hot/Cold pressure fluctuations under the shower can be an annoying problem.

a. Overhead storage tank type. Cold water supply should be piped from hot water storage tank or direct from pressure system through pressure reducing valves.

b. Mains pressure type should present no problems.

c. Mains, low pressure type. The cold water supply should be piped, as close as possible, from the hot water system inlet after the pump and pressure reducing valve.

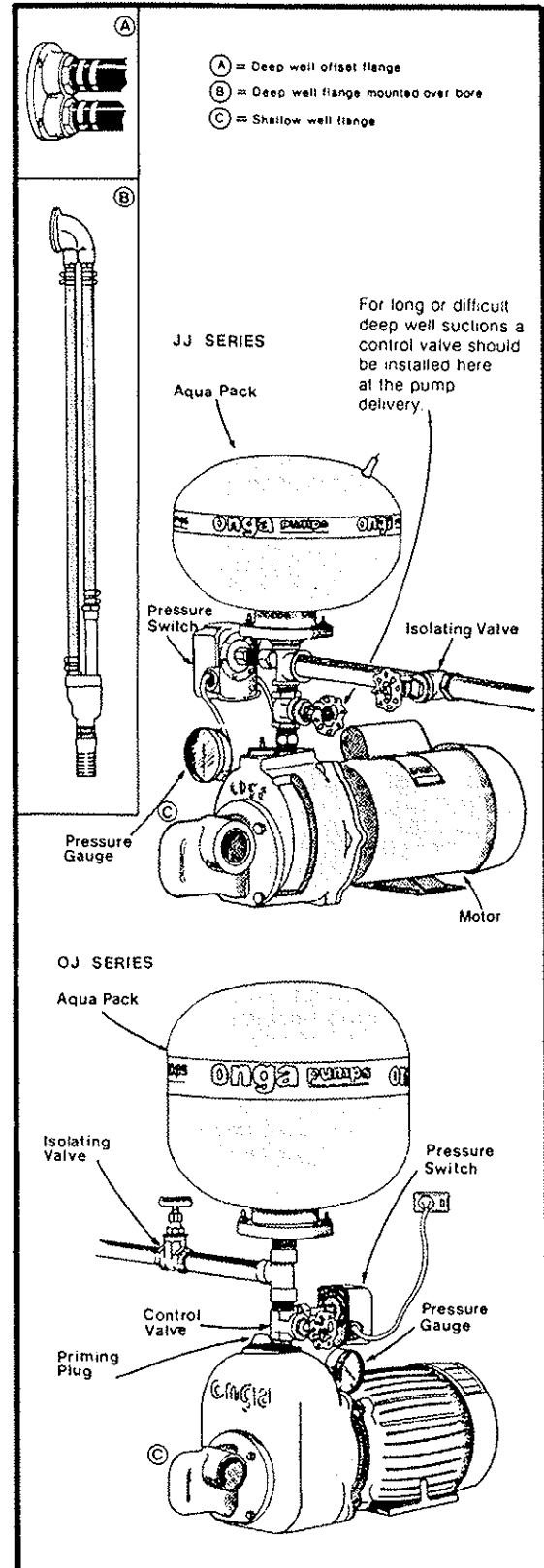

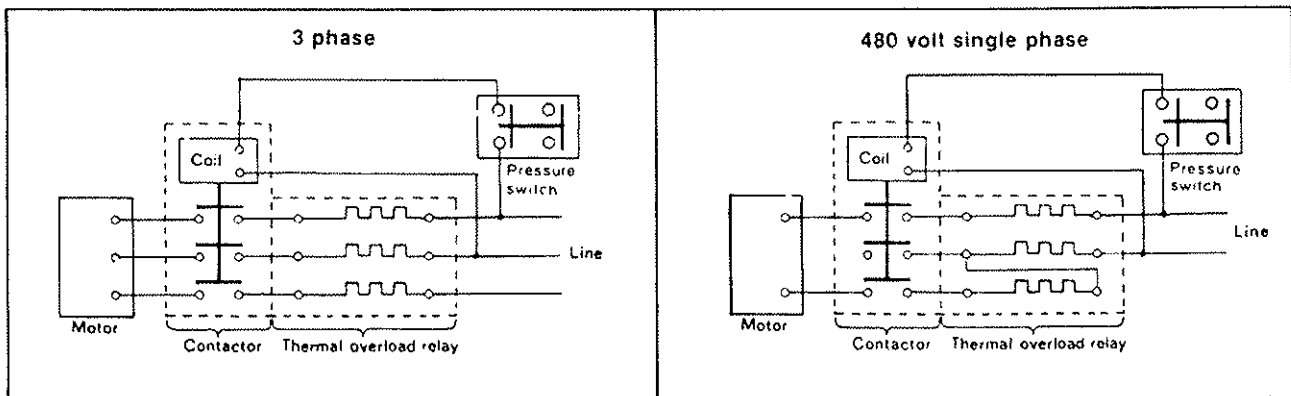

Aqua Pack Maintenance: Check Aqua Pack pressure every six months or when unit on, off cycling increases and recharge pressure if necessary.

To check the aqua pack air pressure turn the pump power off. Then turn on a suitable tap and drain the pump of all water. Then measure the air pressure. This should be the same as the lower pressure switch setting of the pump. If necessary pump up the tank so that the air charge is correct. Do not over charge as this will cause tank liner damage and pressure surge problems with the system.

False pressure readings can be obtained when checking the air pressure unless the tank is empty of water. If in doubt it is good practice to unscrew the tank from the pipework.

Shallow Well Priming: Close control or isolating valve, unscrew priming plug, pour in water until both pump and suction lines are full. Although the pump is self-priming, fill as much of suction line as possible. Replace priming plug loosely to allow any air bleed while maintaining 10 to 20 p.s.i. in the pump. Allow pump to operate until primed. Then open valve so that remaining air is flushed from pump. If priming a long or difficult suction that has not been filled with water, the pump may have to be refilled several times at quarter hour intervals as priming ability decreases when water gets hot.

Deep Well Priming: Close control valve, unscrew priming plug and pour in water until both pump and suction pipes are full. Replace priming plug and turn on pump. Pressure gauge should rise to above 40 p.s.i. Open control valve slowly and flush air from pump and suction pipes. Care should be taken to maintain minimum operating pressure. As deep well pumps are sensitive to air, if pump is not primed at first attempt, repeat. If pump has been installed on an offset or river installation, it may be impossible to install suction pipes to rise evenly from water to pump. To overcome this, a 'T' should be installed in both the suction and pressure pipes at each hump for priming purposes.

Deep Well Minimum Operating Pressure: To obtain maximum capacity, pump should run at minimum operating pressure - see catalogue. If pressure is allowed to drop, pump may lose prime or less than optimum capacity pumped. Minimum operating pressure can be maintained by the back pressure necessary to, say, run a garden sprinkler, or the control valve can be partially closed. (JJ series pumps will operate satisfactorily with adjustment to the isolating valve - if used for deep or difficult suction a suitable control valve should be installed). To set valve, turn on all taps which are likely to be operating at the one time, pump bore down to lowest level and adjust valve so that minimum operating pressure is maintained. OJ pumps come complete with automatic control valve - see separate instruction sheet.

SERVICE

Priming Trouble:

- Foot or check valve may be leaking.
- Foot valve should be installed below lowest water level.
- Suction lift to high.
- Air leak in suction pipe.
- Check valve may be installed in wrong direction.
- Voltage or wiring of motor may be incorrect.

Motor Switching On and Off When No Water is Being Used:

- Pressure switch setting incorrect - check catalogue.
- Aqua Pack filled with water - no air cushion. Recharge to instruction on Aqua Pack. If Aqua Pack loses pressure after a short period of operation, then check Aqua Pack and air valve for leaks, and replace with an onga service Aqua Pack if necessary.
- Foot or check valve leaking.
- Discharge or suction pipe or pipe fittings leaking.

Pump Not Switching Off or Taking Too Long to Switch Off:

- Low line voltage.
 - Drop in suction water level.
 - A leak on discharge side of pump.
 - Blocked impeller or jet.
- To correct for a drop in voltage and/or water level, adjust top pressure switch setting about 5 p.s.i. (35 kPa) below pump top pressure.

Motor Thermal Overload Tripping:

- Motor operating on low voltage.
- A blocked impeller causing it to rub.
- Waterlogged Aqua Pack. To cure see "Motor Switching On and Off" (b) above.
- Motor starter switch sticking.

Minimum Pump Operating Pressure High:

If deep well pumps have a minimum operating pressure of 5 to 7 lbs. above catalogue, this might indicate an air leak on the suction side of pump.

Water Pressure Kits:

Pumps can be supplied in two ways. Suitable to operate as a PUMP only or suitable for use as a WATER PRESSURE SYSTEM (W.P.S.). Pumps can be converted to W.P.S. with or without loss of prime protection. High pressure W.P.S. and some 3 phase W.P.S. are only supplied as pump and appropriate kit. To assemble pump and WPK kit are instructions and the assembly drawings supplied with the kit.

Aqua Pack Charging:

Switch power off. Turn tap on and drain the water pressure system of water. Check air pressure in the onga pack this can be removed from the system by unscrewing it from the pipe work if more convenient. The pressure should be the same as the lower pressure with setting.

i.e. 20lbs/sq ins if Pressure Switch Setting 20-40.

30lbs/sq ins if Pressure Switch Setting 30-50.

If the pressure is low re-charge to correct pressure. If most of the air has been absorbed the tank may be full or partially full of water. When re-charging make sure

that the tap is left turned on and you give the re-charging sufficient time to expell the retained water. This makes sure the Aqua Pack is properly charged with air.

Spare Parts:

When ordering, state pump model, serial number and name describe parts required.



Rainbow Pool Products

PO Box 2388, Mansfield Qld 4122

Telephone STD 61-7-3849 5385

Facsimile STD 61-7-3849 5384

Email: info@rainbowpoolproducts.com.au

Web: www.rainbowpoolproducts.com.au

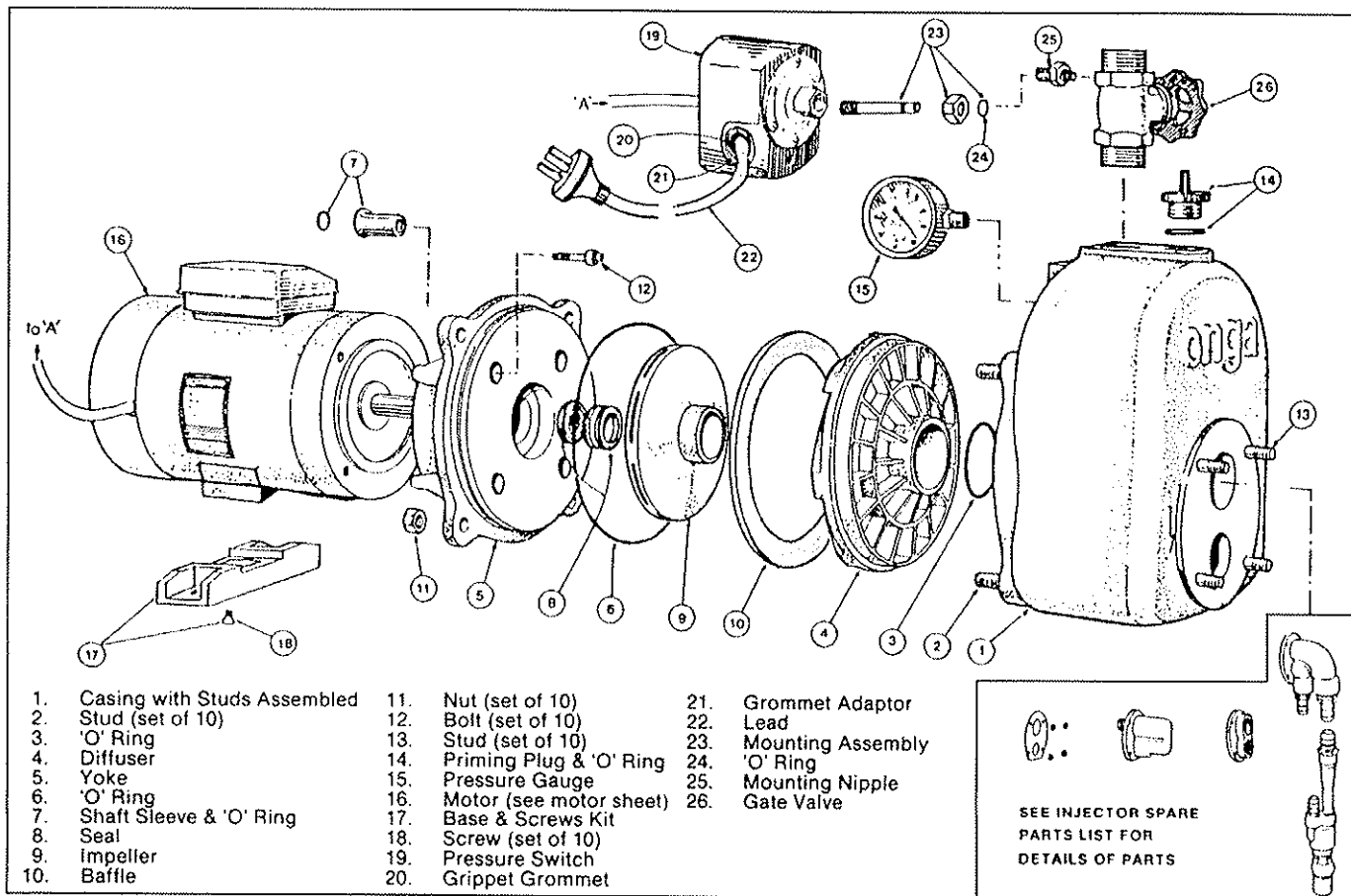

Deep Well Injector - Jet and Venturi Assembly:

Deep well injectors are supplied without the Jet & Venturi assembled.

To assemble the Injector:

1. Take the jet and screw it firmly into the jet housing. No thread seal need be used. Common spark plug spanners will fit the jet and are an ideal tool to use.
2. Using white thread tape to seal the thread screw the venturi into the housing. Care should be taken to firmly tighten the venturi but not to the extent that could cause damage.
3. Using white thread tape to seal the thread screw the pipe fitting supplied to the venturi. Use the same care as in (2) above.
4. Identification tag should be attached to the deep well elbow with the drive screw supplied.
5. For further installation instructions see the instructions supplied with the pump.

