

# Hi-Flow™ Valve

## Installation, Operation & Service Manual

### IMPORTANT SAFETY INSTRUCTIONS

### READ AND FOLLOW ALL INSTRUCTIONS

### SAVE THESE INSTRUCTIONS

#### Table of Contents

SECTION I.	Valve Installation. ....	3
SECTION II.	Winterizing. ....	3
SECTION III.	Replacement of Valve Top and Diverter Assembly. ....	3
SECTION IV.	Complete Disassembly. ....	3
SECTION V.	Technical Data. ....	4

#### WARNING

Before installing this product, read and follow all warning notices and instructions accompanying this valve. Failure to follow safety warnings and instructions can result in severe injury, death, or property damage. Call (800) 831-7133 for additional free copies of these instructions.

#### Important Notice



Attention Installer.

This manual contains important information about the installation, operation and safe use of this product. This information should be given to the owner/operator of this equipment.

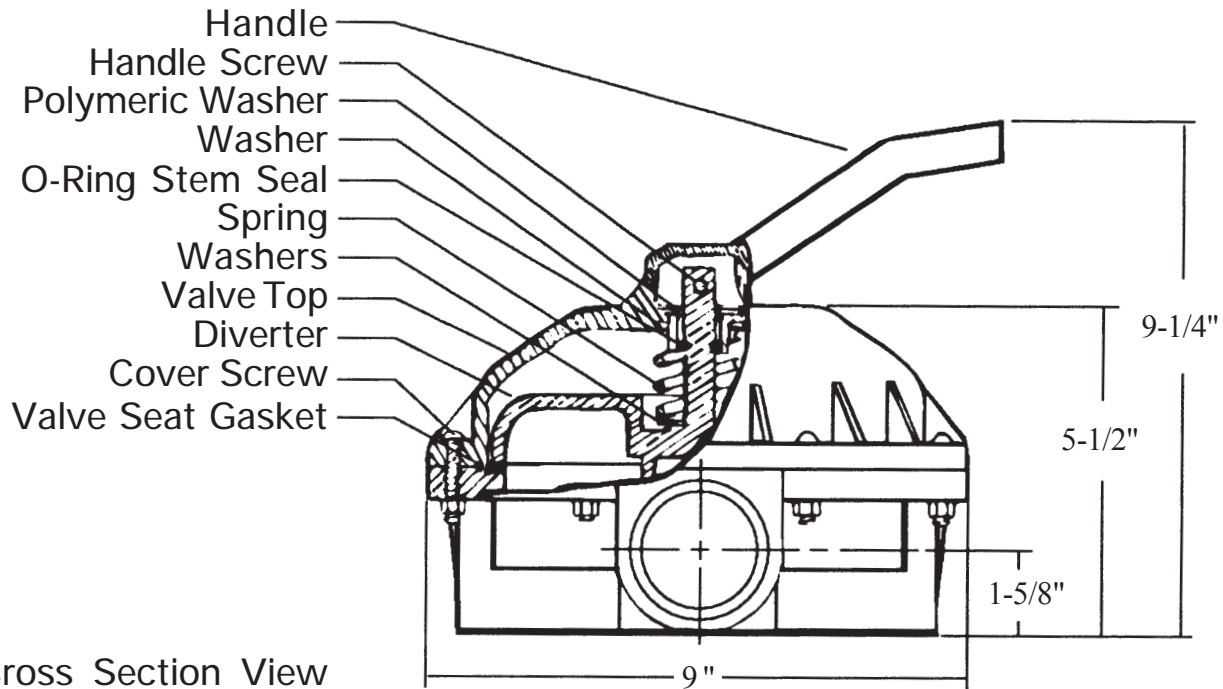

## ⚠ WARNING



CHANGING VALVE POSITIONS WHILE THE PUMP IS RUNNING CAN DAMAGE THE VALVE SEAL AND/OR DEAD HEAD YOUR SYSTEM AND CAN CAUSE SEVERE BODILY AND/OR PROPERTY DAMAGE. ALWAYS TURN THE PUMP OFF BEFORE CHANGING VALVE POSITIONS.

## VALVE POSITIONS

SETTING	FLOW PATH
FILTER	PUMP - SAND TOP/DE BOTTOM - THRU FILTER - DE TOP/SAND BOTTOM - RETURN For normal filter action and vacuuming pool thru filter.
BACKWASH	PUMP - DE TOP/SAND BOTTOM - THRU FILTER - SAND TOP/DE BOTTOM - WASTE For cleaning filter by reversing flow.
RINSE	PUMP - DE TOP/SAND BOTTOM - THRU FILTER - DE TOP/SAND BOTTOM - WASTE For start-up cleaning and resetting filter bed after backwashing.
WASTE	PUMP-WASTE For vacuuming directly to waste, lowering pool level or draining pool.
CLOSED	NO CIRCULATION - DO NOT USE THIS SETTING WITH PUMP OPERATING
RECIRCULATE	PUMP - RETURN For circulating water without going thru filter.

## SECTION I. Valve Installation.

### CAUTION

This valve is available in two models for use with sand type or diatomaceous earth (DE) type pool filters. Be certain that you have the correct model for your filter. Installing the incorrect model may cause your pump to dead head, or drain the pool when in the backwash position.

1. Confirm correct valve is being used; DE valves for DE filters and Sand valve for Sand filters.
2. Install valve to filter by securing bulkhead nuts on valve to fittings on filter.



### CAUTION

Tighten the nuts by hand only - no additional tightness is required.

3. Plumb pump piping to center pipe in valve.
4. Plumb return and waste lines.

## SECTION II. Winterizing.

1. Drain and winterize pump and filter per manufacturer's instructions.
2. Depress valve handle and rotate so pointer on handle is between any two settings.

## SECTION III. Replacement of Valve Top and Diverter Assembly.

1. Set valve handle in any setting.
2. Remove coverscrews.
3. Lift off valve top and diverter assembly.
4. Install new valve top and diverter assembly making sure arrows on valve top and bottom are aligned.
5. Tighten cover screws evenly and alternately. Do not overtighten.

## SECTION IV. Complete Disassembly.

1. Remove handle to diverter screw. Note arrow on top of diverter stem as handle is removed.
2. Evenly and alternately loosen cover screws.

### CAUTION

Top is under spring load. Loosen all screws before removing any of them.

3. Remove cover screws and then valve top.
4. Note location of O-ring and spring and number of washers on diverter stem. Remove O-Ring, spring and washers.
5. Assemble in reverse order.

### NOTE

Prior to assembly, insure bottom gasket and diverter sealing surface are clean and free from nicks to insure positive sealing.

6. When replacing valve handle, make sure arrow on diverter stem and pointer on handle are pointed in the same direction.



### CAUTION

Do NOT overtighten the screws, or use motorized screwdrivers; as this can cause damage to the threads.

## SECTION V. Technical Data.

### A. Replacement Parts

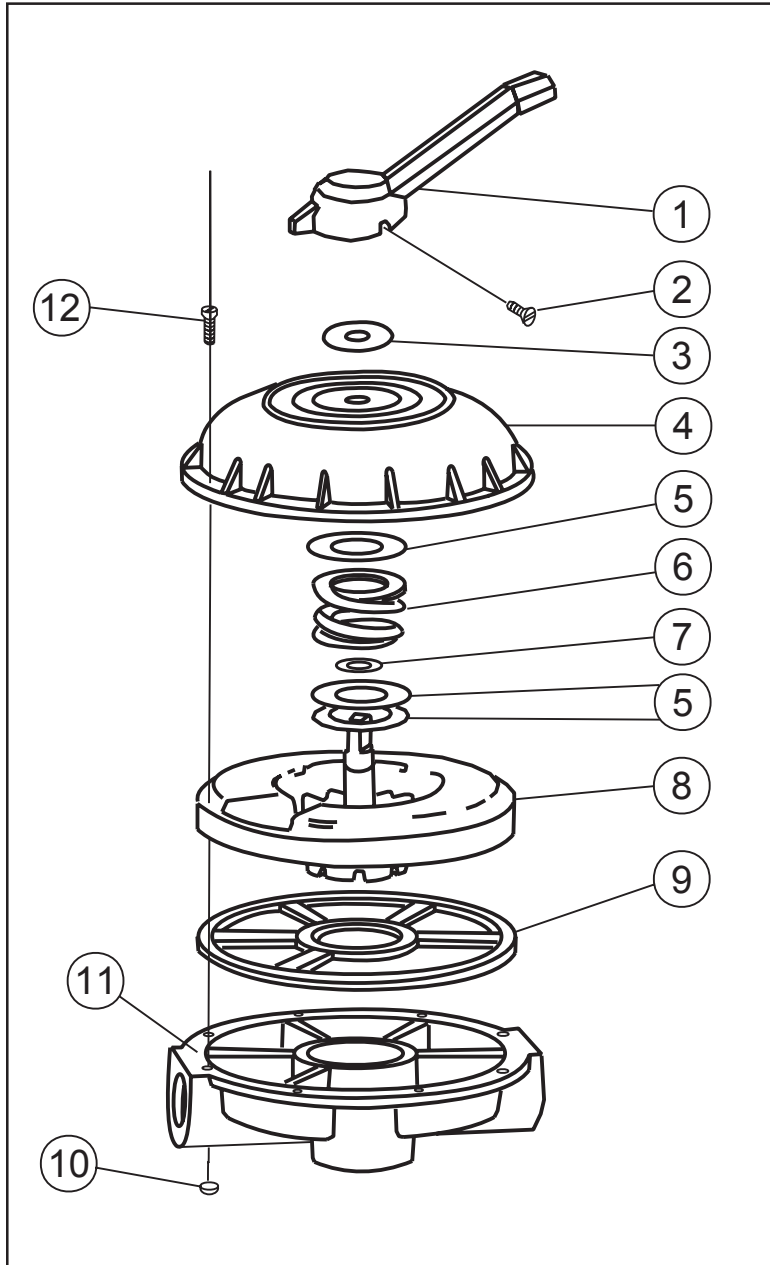

This Form Covers Assemblies  
26-1049  
26-1050  
26-1142

Item	P/N	Description	Qty.
1	27-2411	Handle	1
2	27-2405	Screw - Handle	1
3	27-2402	Washer, Plastic	1
4	27-2412	Valve Top	1
5	27-2401	Washer - 1/32 in.	3
6	27-2400	Spring - Compression	1
7	27-2406	O-ring - Diverter	1
8	27-2413	Diverter	1
9	27-2409	Seal - Diverter	1
10	98211400	Nut - 1/4 in. - 20 Hex	8
11	27-2415	Plate - 2 in. Valve Bottom	1
12	27-2403	Screw - 1/4 in. - 20	8
	27-2422*	Valve Top Assy.	1

\* This part number includes items 1 thru 9.

#### NOTE

When replacing gasket P/N 27-2409, secure it to valve bottom with an instant cyanoacrylate adhesive suitable for bonding rubber to plastic such as Permabond #102 or a similar product available from an industrial supply retailer.



## Rainbow Pool Products

PO Box 2388, Mansfield Qld 4122

Telephone STD 61-7-3849 5385

Facsimile STD 61-7-3849 5384

Email: [info@rainbowpoolproducts.com.au](mailto:info@rainbowpoolproducts.com.au)

Web: [www.rainbowpoolproducts.com.au](http://www.rainbowpoolproducts.com.au)

SAVE THESE INSTRUCTIONS.