

# LEISURETIME AGP

## ABOVE GROUND PUMPS



Leisuretime Above Ground Pump



### Featured Highlights

- **IPX5 Totally Enclosed Fan Cooled Motor (TEFC)** - protects against water and dust whilst keeping the motor cool.
- Self-priming.
- Built in on-winding thermal overload motor protection.
- Electrophoretic coated end-shield.
- Stainless steel shaft and mechanical seal.
- 2 year limited warranty.\*

The Leisuretime range of above ground pool pumps are great economical pumps ideal for small to medium above ground pool systems. Sized from 1/2 to 1Hp they are purposefully designed to provide maximum performance at a realistic cost.

### Ordering Information

Part	Model	Voltage (VAC)	Full Load (A)	Power Input (P1,W)	Power Output (P2,W)	Nominal Power (hp)	Locked Rotor Current (A)	Capacitor (uF)	Carton Dim(mm).	Carton Weight (Kg.)	Pallet Qty.
HIGH PERFORMANCE SINGLE PHASE											
LTP400A	Leisuretime Above Ground 400	230-240	2.7	585	400	0.5	10	12	450x220x310	8.5	48
LTP550A	Leisuretime Above Ground 550	230-240	3.5	785	550	0.75	17	20	450x220x310	11.5	48
LTP750A	Leisuretime Above Ground 750	230-240	4.3	930	700	1	17	20	450x220x310	11.5	48

### Dimensions and Performance

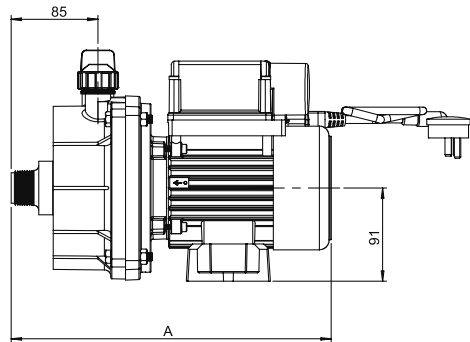
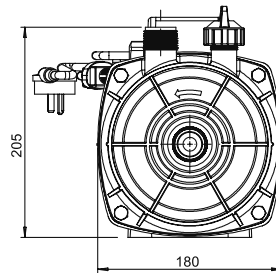
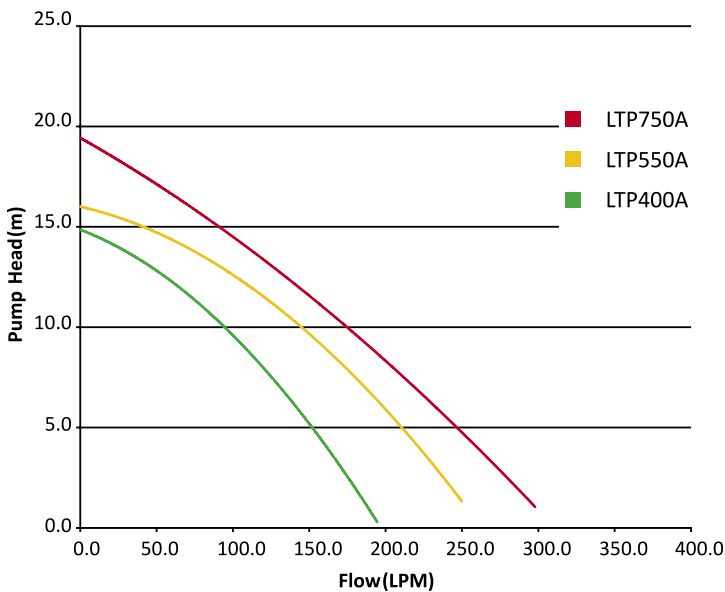

Pump Model	LTP400A	LTP550A	LTP750A
A (mm)	313	322	322

\*All dimensions in mm.

\*Terms and conditions apply



### Rainbow Pool Products

PO Box 2388, Mansfield Qld 4122

Telephone STD 61-7-3849 5385

Facsimile STD 61-7-3849 5384

Email: [info@rainbowpoolproducts.com.au](mailto:info@rainbowpoolproducts.com.au)

Web: [www.rainbowpoolproducts.com.au](http://www.rainbowpoolproducts.com.au)