

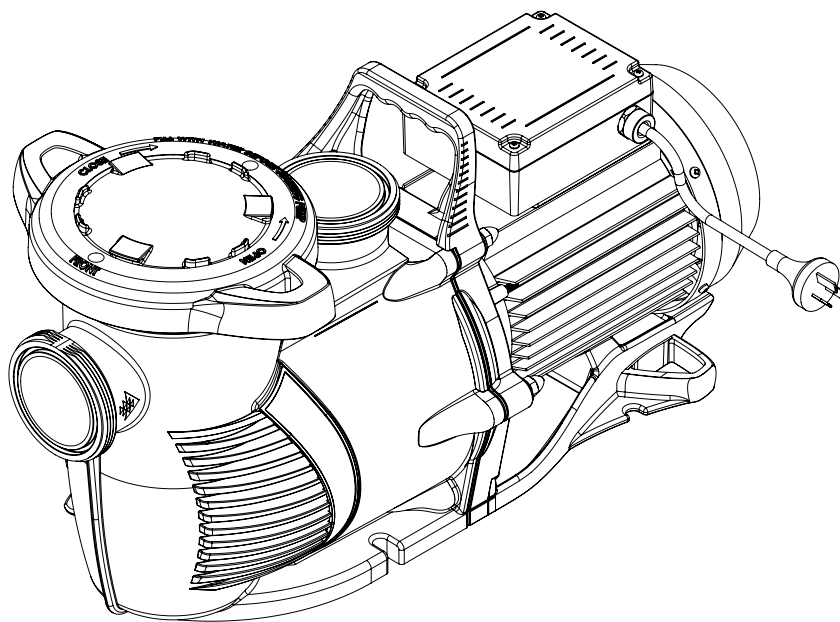

WHISPERFLOXF™

HIGH PERFORMANCE PUMP



Rainbow Pool Products

PO Box 2388, Mansfield Qld 4122

Telephone STD 61-7-3849 5385

Facsimile STD 61-7-3849 5384

Email: info@rainbowpoolproducts.com.au

Web: www.rainbowpoolproducts.com.au

INSTALLATION AND USER'S GUIDE

IMPORTANT SAFETY INSTRUCTIONS
READ AND FOLLOW ALL INSTRUCTIONS
SAVE THESE INSTRUCTIONS

CUSTOMER SERVICE / TECHNICAL SUPPORT

If you have questions about ordering Pentair Aquatic Systems replacement parts, and pool products, please contact:

Customer Service

(7 A.M. to 6 P.M. — Eastern Standard Time)

Phone: 1300 137 344

Fax: 1800 006 668

Web site

Visit www.pentairwater.com.au for more information about Pentair products.

Technical Support

(8 A.M. to 5 P.M. — Eastern Standard Time)

Melbourne, Victoria

Phone: 1300 137 344

Fax: 1800 006 668

TABLE OF CONTENTS

Important Pump Warning and Safety Instructions	ii	Servicing	5
Pump Overview	1	Motor Care	5
Pump Overview and Features	1	Pump Disassembly	5
Union Adapter Installation	1	Pump Reassembly	6
Electrical Wiring Installation	2	The Mechanical Seal	6
Operating the Pump	3	Troubleshooting	7
Priming the Pump	3	Replacement Parts	8
Maintenance	4	Illustrated Parts List	8
Pump Strainer Basket	4	Pump Dimensions	9
Cleaning the Pump Strainer Basket	4	Pump Performance Curves	10
Winterizing	4		

© 2012 Pentair Aquatic Systems. All rights reserved.

This document is subject to change without notice.

1-21 Monash Drive, Dandenong South, VIC3175 • 1300 137 344

www.pentairwater.com.au

All Pentair trademarks and logos are owned by Pentair, Inc. Pentair Aquatic Systems™ and WhisperFloXF™ are trademarks and/or registered trademarks of Pentair Water Pool and Spa, Inc. and/or its affiliated companies in the United States and/ or other countries. Unless expressly noted, names and brands of third parties that may be used in this document are not used to indicate an affiliation or endorsement between the owners of these names and brands and Pentair Water Pool and Spa, Inc. Those names and brands may be the trademarks or registered trademarks of those third parties. Because we are continuously improving our products and services, Pentair reserves the right to change specifications without prior notice. Pentair is an equal opportunity employer.

P/N L300203 B1012

IMPORTANT PUMP WARNING AND SAFETY INSTRUCTIONS



IMPORTANT NOTICE

This guide provides installation and operation instructions for the WhisperFloXF™ High Performance Pump. Consult Pentair with any questions regarding this equipment.

Attention Installer: This guide contains important information about the installation, operation and safe use of this product. This information should be given to the owner and/or operator of this equipment after installation or left on or near the pump.

Attention User: This manual contains important information that will help you in operating and maintaining this product. Please retain it for future reference.

READ AND FOLLOW ALL INSTRUCTIONS SAVE THESE INSTRUCTIONS



This is the safety alert symbol. When you see this symbol on your system or in this manual, look for one of the following signal words and be alert to the potential for personal injury.

DANGER

Warns about hazards that can cause death, serious personal injury, or major property damage if ignored.

WARNING

Warns about hazards that may cause death, serious personal injury, or major property damage if ignored.

CAUTION

Warns about hazards that may or can cause minor personal injury or property damage if ignored.

NOTE indicates special instructions not related to hazards.

Carefully read and follow all safety instructions in this manual and on equipment. Keep safety labels in good condition; replace if missing or damaged.

When installing and using this electrical equipment, basic safety precautions should always be followed, include the following:

WARNING Do not permit children to use this product.

WARNING **RISK OF ELECTRICAL SHOCK.** Connect only to a branch circuit protected by a ground-fault circuit-interrupter (GFCI). Contact a qualified electrician if you cannot verify that the circuit is protected by a GFCI.

WARNING This unit must be connected only to a supply circuit that is protected by a ground-fault circuit-interrupter (GFCI). Such a GFCI should be provided by the installer and should be tested on a routine basis. To test the GFCI, push the test button. The GFCI should interrupt power. Push the reset button. Power should be restored. If the GFCI fails to operate in this manner, the GFCI is defective. If the GFCI interrupts power to the pump without the test button being pushed, a ground current is flowing, indicating the possibility of an electric shock. Do not use this pump. Disconnect the pump and have the problem corrected by a qualified service representative before using.

CAUTION This pump is for use with permanent swimming pools and may also be used with hot tubs and spas if so marked. Do not use with storable pools. A permanently-installed pool is constructed in or on the ground or in a building such that it cannot be readily disassembled for storage. A storable pool is constructed so that it is capable of being readily disassembled for storage and reassembled to its original integrity.

General Warnings

- Never open the inside of the drive motor enclosure. There is a capacitor bank that holds a 230 VAC charge even when there is no power to the unit.
- The pump is not submersible.
- The pump is capable of high flow rates; use caution when installing and programming to limit pumps performance potential with old or questionable equipment.
- Code requirements for the electrical connection differ from state to state. Install equipment in accordance with the National Electrical Code and all applicable local codes and ordinances.
- Before servicing the pump; switch OFF power to the pump by disconnecting the main circuit to the pump.
- This appliance is not intended for use by persons (including children) of reduced physical, sensory or mental capabilities, or lack of experience and knowledge, unless they have been given supervision or instruction concerning the use of the appliance by a person responsible for their safety.

DANGER FAILURE TO FOLLOW ALL INSTRUCTIONS AND WARNINGS CAN RESULT IN SERIOUS BODILY INJURY OR DEATH. **THIS PUMP SHOULD BE INSTALLED AND SERVICED ONLY BY A QUALIFIED POOL SERVICE PROFESSIONAL. INSTALLERS, POOL OPERATORS AND OWNERS MUST READ THESE WARNINGS AND ALL INSTRUCTIONS IN THE OWNER'S MANUAL BEFORE USING THIS PUMP. THESE WARNINGS AND THE OWNER'S MANUAL MUST BE LEFT WITH THE POOL OWNER.**

DANGER SUCTION ENTRAPMENT HAZARD: STAY OFF THE MAIN DRAIN AND AWAY FROM ALL SUCTION OUTLETS!

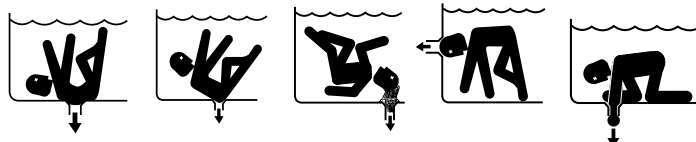

THIS PUMP PRODUCES HIGH LEVELS OF SUCTION AND CREATES A STRONG VACUUM AT THE MAIN DRAIN AT THE BOTTOM OF THE BODY OF WATER. THIS SUCTION IS SO STRONG THAT IT CAN TRAP ADULTS OR CHILDREN UNDER WATER IF THEY COME IN CLOSE PROXIMITY TO A DRAIN OR A LOOSE OR BROKEN DRAIN COVER OR GRATE.

THE USE OF UNAPPROVED COVERS OR ALLOWING USE OF THE POOL OR SPA WHEN COVERS ARE MISSING, CRACKED OR BROKEN CAN RESULT IN BODY OR LIMB ENTRAPMENT, HAIR ENTANGLEMENT, BODY ENTRAPMENT, EVISCERATION AND/OR DEATH. The suction at a drain or outlet can cause:

Limb Entrapment: When a limb is sucked or inserted into an opening resulting in a mechanical bind or swelling. This hazard is present when a drain cover is missing, broken, loose, cracked or not properly secured.

Hair Entanglement: When the hair tangles or knots in the drain cover, trapping the swimmer underwater. This hazard is present when the flow rating of the cover is too small for the pump or pumps.

Body Entrapment: When a portion of the body is held against the drain cover trapping the swimmer underwater. This hazard is present when the drain cover is missing, broken or the cover flow rating is not high enough for the pump or pumps.

Evisceration/Disembowelment: When a person sits on an open pool (particularly a child wading pool) or spa outlet and suction is applied directly to the intestines, causing severe intestinal damage. This hazard is present when the drain cover is missing, loose, cracked, or not properly secured.

IMPORTANT PUMP WARNING AND SAFETY INSTRUCTIONS

Mechanical Entrapment: When jewelry, swimsuit, hair decorations, finger, toe or knuckle is caught in an opening of an outlet or drain cover. This hazard is present when the drain cover is missing, broken, loose, cracked, or not properly secured.

NOTE: ALL SUCTION PLUMBING MUST BE INSTALLED IN ACCORDANCE WITH THE LATEST NATIONAL AND LOCAL CODES, STANDARDS AND GUIDELINES.

⚠ WARNING TO MINIMIZE THE RISK OF INJURY DUE TO SUCTION ENTRAPMENT HAZARD:

- A properly installed and secured ANSI/ASME A112.19.8 approved anti-entrapment suction cover must be used for each drain.
- Each suction cover must be installed at least three (3') feet apart, as measured from the nearest point to nearest point.
- Regularly inspect all covers for cracks, damage and advanced weathering.
- If a cover becomes loose, cracked, damaged, broken or is missing, replace with an appropriate certified cover.
- Replace drain covers as necessary. Drain covers deteriorate over time due to exposure to sunlight and weather.
- Avoid getting hair, limbs or body in close proximity to any suction cover, pool drain or outlet.
- Disable suction outlets or reconfigure into return inlets.

⚠ WARNING A clearly labeled emergency shut-off switch for the pump must be in an easily accessible, obvious place. Make sure users know where it is and how to use it in case of emergency.

The Virginia Graeme Baker (VGB) Pool and Spa Safety Act creates new requirements for owners and operators of commercial swimming pools and spas.

Commercial pools or spas constructed on or after December 19, 2008, shall utilize:

(A) A multiple main drain system without isolation capability with suction outlet covers that meet ASME/ANSI A112.19.8a Suction Fittings for Use in Swimming Pools, Wading Pools, Spas, and Hot Tubs and either:

- A safety vacuum release system (SVRS) meeting ASME/ANSI A112.19.17 Manufactured Safety Vacuum Release systems (SVRS) for Residential and Commercial Swimming Pool, Spa, Hot Tub, and Wading Pool Suction Systems and/or ASTM F2387 Standard Specification for Manufactured Safety Vacuum Release Systems (SVRS) for Swimming pools, Spas and Hot Tubs or
- A properly designed and tested suction-limiting vent system or
- An automatic pump shut-off system.

Commercial pools and spas constructed prior to December 19, 2008, with a single submerged suction outlet shall use a suction outlet cover that meets ASME/ANSI A112.19.8a and either:

- A SVRS meeting ASME/ANSI A112.19.17 and/or ASTM F2387, or
- A properly designed and tested suction-limiting vent system, or
- An automatic pump shut-off system, or
- Disabled submerged outlets, or
- Suction outlets shall be reconfigured into return inlets.

For Installation of Electrical Controls at Equipment Pad (ON/OFF Switches, Timers and Automation Load Center)

⚠ CAUTION Install all electrical controls at equipment pad, such as on/off switches, timers, and control systems, etc. to allow the operation (startup, shut-down, or servicing) of any pump or filter so the user does not place any portion of his/her body over or near the pump strainer lid, filter lid or valve closures. This installation should allow the user enough space to stand clear of the filter and pump during system start-up, shut down or servicing of the system filter.



⚠ DANGER



HAZARDOUS PRESSURE: STAND CLEAR OF PUMP AND FILTER DURING START UP

Circulation systems operate under high pressure. When any part of the circulating system (i.e. locking ring, pump, filter, valves, etc.) is serviced, air can enter the system and become pressurized.

Pressurized air can cause the pump housing cover, filter lid, and valves to violently separate which can result in severe personal injury or death. Filter tank lid and strainer cover must be properly secured to prevent violent separation. Stand clear of all circulation system equipment when turning on or starting up pump.

Before servicing equipment, make note of the filter pressure. Be sure that all controls are set to ensure the system cannot inadvertently start during service. Turn off all power to the pump. **IMPORTANT: Place filter manual air relief valve in the open position and wait for all pressure in the system to be relieved.**

Before starting the system, fully open the manual air relief valve and place all system valves in the "open" position to allow water to flow freely from the tank and back to the tank. Stand clear of all equipment and start the pump.

IMPORTANT: Do not close filter manual air relief valve until all pressure has been discharged from the valve and a steady stream of water appears. Observe filter pressure gauge and be sure it is not higher than the pre-service condition.

General Installation Information

- All work must be performed by a qualified service professional, and must conform to all national, state, and local codes.
- Install to provide drainage of compartment for electrical components.
- These instructions contain information for a variety of pump models and therefore some instructions may not apply to a specific model. All models are intended for use in swimming pool applications. The pump will function correctly only if it is properly sized to the specific application and properly installed.

⚠ WARNING Pumps improperly sized or installed or used in applications other than for which the pump was intended can result in severe personal injury or death. These risks may include but not be limited to electric shock, fire, flooding, suction entrapment or severe injury or property damage caused by a structural failure of the pump or other system component.

⚠ WARNING The pump can produce high levels of suction within the suction side of the plumbing system. These high levels of suction can pose a risk if a person comes within the close proximity of the suction openings. A person can be seriously injured by this high level of vacuum or may become trapped and drown. It is absolutely critical that the suction plumbing be installed in accordance with the latest national and local codes for swimming pools.

Warnings and safety instructions for Pentair Aquatic Systems pumps and other related products are available at: <http://www.pentairpool.com/pool-owner/safety-warnings/> or call (800) 831-7133 for additional free copies of these instructions.

Please refer to <http://www.pentairpool.com/pool-owner/safetywarnings/> for warning and safety instructions related to the this product.

SAVE THESE INSTRUCTIONS

PUMP OVERVIEW

The WhisperFloXF™ High Performance Pump is specifically designed to be the best choice for a variety of inground pools. A heavy duty 56 square flange motor, and highly engineered hydraulics make this rugged and tested design perfect for any pool, spa, water feature, or fountain.

- Extremely quiet operation
- See-through lid permits easy inspection of strainer basket
- Self-priming for quick, easy start-up
- Unionized fittings (2.5" and 3") for simple replacement
- Cam and Ramp™ lid for easy cleaning and maintenance
- Heavy-duty, high service factor 56 square flange motor for long life
- "Diamond Seal" O-rings for superior seal performance
- Integral volute and pot reduce hydraulic noise
- Every WhisperFloXF pump is pressure tested prior to shipment to ensure superior quality.
- Approved to AS/NZS 60335.2.41

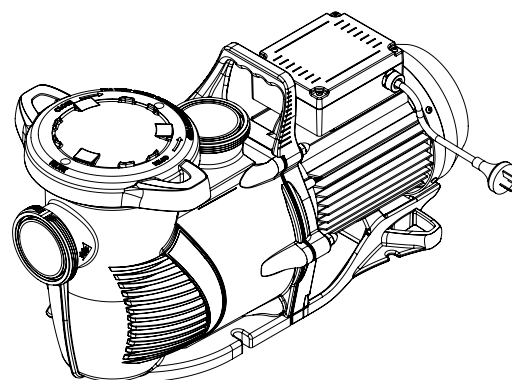

WhisperFloXF™ Pump (Black)

*Drop-in replacement for all WhisperFlo models.
Simple replacement for Challenger® pumps
(Riser base required for Challenger replacements
P/N 400012 available separately)*

Union Adapter Installation

Installing the locking union onto the pump:

1. Glue the PVC union adapter fitting to the PVC pipe. The adapter accepts 2.5" PVC pipe internally or a 3" PVC coupling externally.

Note: Be sure that the groove for the retainer ring is on the end opposite your glue joint.

2. Slip the nut onto the fitting.
3. Place the flat side of the retainer ring against the adapter on the grooved end.
4. Gently flex the locking clip union nut retainer ring into its place in the groove on the adapter.
5. Start snapping it in at one end of the ring and work your way around.

The tab features should point out away from the nut and the glue joint towards the sealing surface.

6. Slide the nut over the ring and attach it to the pump.

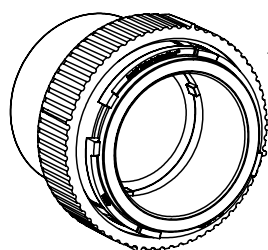

Union Nut and Adapter

Only install the retainer ring with the tab features pointing away from the nut.

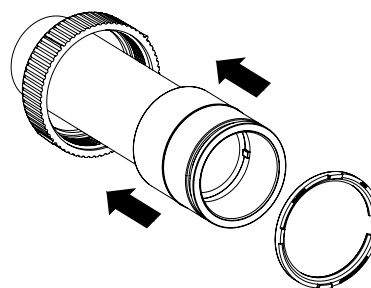

Slip the nut onto the fitting.

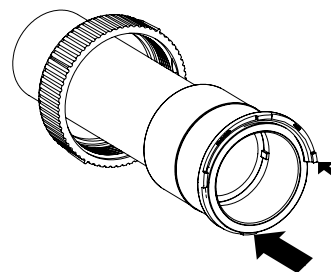

Snap retainer ring around the adapter.

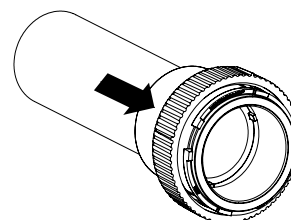

Slide the nut over the adapter

ELECTRICAL WIRING INSTALLATION

⚠ WARNING



RISK OF ELECTRICAL SHOCK OR ELECTROCUTION. This pump must be installed by a licensed or certified electrician or a qualified service professional in accordance with the National Electrical Code and all applicable local codes and ordinances. Improper installation will create an electrical hazard which could result in death or serious injury to users, installers, or others due to electrical shock, and may also cause damage to property.

Always disconnect power to the pump at the circuit breaker before servicing the pump. Failure to do so could result in death or serious injury to service people, users or others due to electric shock.

Read all servicing instructions before working on the pump.

To connect the pump to an AC power source:

1. Be sure all electrical breakers and switches are turned off before wiring motor.
2. Be sure that the supply line voltage matches the motor voltage listed on the motor plate (example 240 VAC). If they do not match, permanent motor damage may occur.
3. Connect the supply cord to a 15A weatherproof outlet.
4. If equipotential bonding is required, connect all metal parts of the swimming pool, spa, or hot tub structure and to all electrical equipment, metal conduit, and metal piping in accordance with the wiring rules. Run a wire from the equipotential bonding terminal to the pool bonding structure.
5. The pump should be permanently connected to either an RCD in the fixed wiring dedicated to the pump, that has no other electrical loads.

Note: When the pump is started and stopped by removing power with a relay or timer, a two-pole device should be used to apply and remove power to both **POWER LINE TERMINALS**.

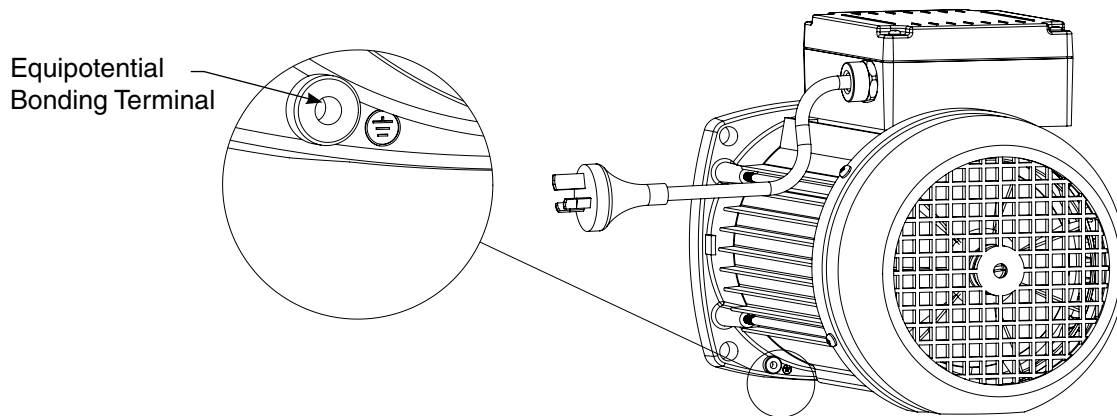

Equipotential Bonding Connection

OPERATING THE PUMP

CAUTION

DO NOT run the pump dry. If the pump is run dry, the mechanical seal will be damaged and the pump will start leaking. If this occurs, the damaged seal must be replaced. ALWAYS maintain proper water level in your pool (half way up skimmer opening). If the water level falls below the skimmer opening, the pump will draw air through the skimmer, losing the prime and causing the pump to run dry, resulting in a damaged seal. Continued operation in this manner could cause a loss of pressure, resulting in damage to the pump case, impeller and seal and may cause property damage and personal injury.

Before turning the pump ON, be sure the following conditions are met:

1. Open filter air relief valve.
2. Open valves.
3. Pool return is completely open and clear of any blockages.
4. Water in the pump basket.
5. Stand clear of the filter or other pressurized vessels.

Priming the Pump

If the WhisperFloXF™ High Performance pump is installed below the water level of the pool, close return and suction lines prior to opening hair and lint pot on pump. Be sure to reopen valves prior to operating.

Note: Running the pump dry could cause a loss of pressure, resulting in damage to the pump case, impeller and seal.

The pump strainer pot must be filled with water before the pump is initially started. Follow the steps below to prime the pump:

1. Remove the pump lid and locking ring.
2. Fill the pump strainer pot with water.
3. Reassemble the pump lid and locking ring onto the strainer pot. The pump is now ready to prime.
4. Open the air relief valve on the filter, and stand clear of the filter.
5. Turn on the pump.
6. When water comes out of the filter air relief valve, close the valve. The system should now be free of air and recirculating water to and from the pool.
7. This pump will prime within 20 minutes. Do not allow your pump to run longer than this time without developing full flow. If the pump does not prime, see the “Troubleshooting” section on page 7.
8. Two speed pumps should run on high speed for priming.

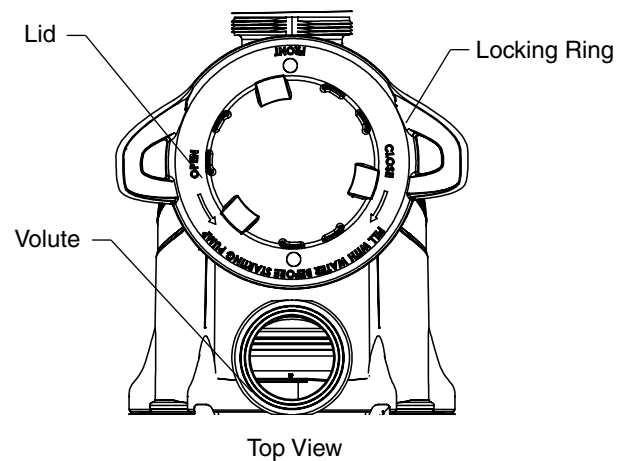

Close Lid/Locking Ring handles in horizontal position

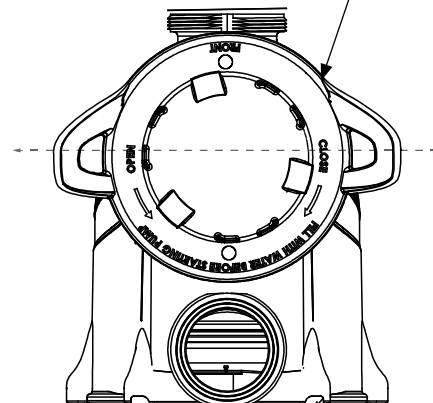

MAINTENANCE

⚠ WARNING

DO NOT open the strainer pot if pump fails to prime or if pump has been operating without water in the strainer pot. Pumps operated in these circumstances may experience a build up of vapor pressure and may contain scalding hot water. Opening the pump may cause serious personal injury. In order to avoid the possibility of personal injury, make sure the suction and discharge valves are open and strainer pot temperature is cool to touch, then open with extreme caution.

⚠ CAUTION

To prevent damage to the pump and for proper operation of the system, clean pump strainer and skimmer baskets regularly.

Pump Strainer Basket

The strainer basket (or 'strainer pot'), is located in front of the pump housing. The strainer basket must be kept clean and free of debris. Inspect basket through the lid on the top of the housing.

Be sure to visually inspect the strainer basket at least once a week. Dirty strainer baskets reduce filter and heater efficiency and put abnormal stress on the pump motor.

Cleaning the Pump Strainer Basket

1. Turn off the pump at the circuit breaker.
 2. Relieve pressure in the system.
 3. Turn the lid and locking ring counter-clockwise and remove from the pump.
 4. Remove debris and rinse out the basket. Replace the basket if it is cracked.
 5. Put the basket back into the housing. Be sure to align the notch in the bottom of the basket with the rib in the bottom of the volute.
 6. Fill the pump pot and volute up to the inlet port with water.
 7. Clean the lid and locking ring, O-ring, and sealing surface of the pump pot.
- Note:** It is important to keep the lid O-ring clean and well lubricated.
8. Reinstall the lid by placing the lid and locking ring on the pot. Be sure the lid O-ring is properly placed. Seat the lid and locking ring on the pump then turn clockwise until the locking ring handles are horizontal.
 9. Open the manual air relief valve on top of the filter, and stand clear of the filter.
 10. Turn on the pump at the circuit breaker.
 11. When water comes out of the air release valve, close the valve.

⚠ WARNING

THIS SYSTEM OPERATES UNDER HIGH PRESSURE. When any part of the circulating system (e.g., Lock Ring, Pump, Filter, Valves, etc.) is serviced, air can enter the system and become pressurized. Pressurized air can cause the lid to separate which can result in serious injury, death, or property damage.

To avoid this potential hazard, follow above instructions.



Winterizing

- In mild climate areas, when temporary freezing conditions may occur, run your filtering equipment all night to prevent freezing.
- You are responsible for determining when freezing conditions may occur. If freezing conditions are expected, take the following steps to reduce the risk of freeze damage. Freeze damage is not covered under warranty.

To prevent freeze damage follow the procedures listed below:

1. Shut off electrical power for the pump at the house circuit breaker.
2. Drain the water out of the pump housing by removing the two thumb-twist drain plugs from the housing. Store the plugs in the pump basket.
3. Cover the motor to protect it from severe rain, snow and ice.

Note: Do not wrap motor with plastic or other air tight materials during winter storage. The motor may be covered during a storm, winter storage, etc., but never when operating or expecting operation.

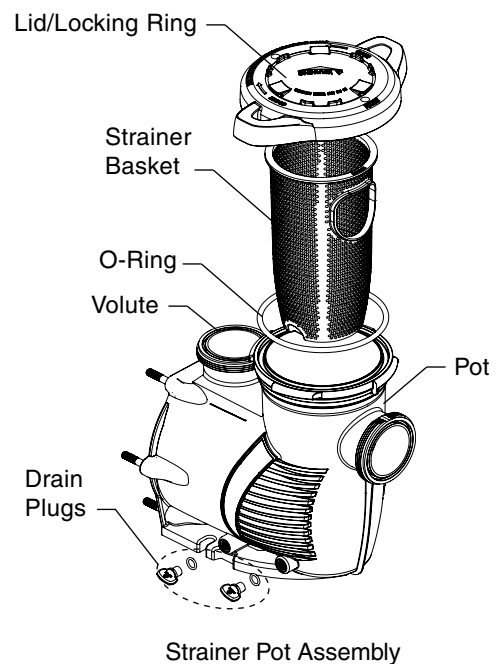

SERVICING

⚠ WARNING

Always disconnect power to the pump at the circuit breaker and disconnect the communication cable before servicing the pump. Failure to do so could result in death or serious injury to service people, users or others due to electric shock. Read all servicing instructions before working on the pump.

⚠ WARNING

DO NOT open the strainer pot if pump fails to prime or if pump has been operating without water in the strainer pot. Pumps operated in these circumstances may experience a build up of vapor pressure and may contain scalding hot water. Opening the pump may cause serious personal injury. In order to avoid the possibility of personal injury, make sure the suction and discharge valves are open and strainer pot temperature is cool to touch, then open with extreme caution.

⚠ CAUTION

Be sure not to scratch or mar the polished shaft seal faces; seal will leak if faces are damaged. The polished and lapped faces of the seal could be damaged if not handled with care.

Motor Care

Protect from heat

1. Shade the motor from the sun.
2. Any enclosure must be well ventilated to prevent overheating.
3. Provide ample cross ventilation.

Protect against dirt

1. Protect from any foreign matter or splashing water.
2. Do not store (or spill) chemicals on or near the motor.
3. Protect from any foreign matter or splashing water.
4. Avoid sweeping or stirring up dust near the motor while it is operating.
5. If a motor has been damaged by dirt it voids the motor warranty.
6. Clean the lid and locking ring O-ring, and sealing surface of the pump pot.

Protect against moisture

1. Protect from splashing or sprayed water.
2. Protect from extreme weather.
3. Protect from any foreign matter or splashing water.
4. If a motor has become wet - let it dry before operating. Do not allow the pump to operate if it has been flooded.
5. If a motor has been damaged by water it voids the motor warranty.

The Mechanical Seal

The mechanical seal consists primarily of two parts, a rotating member and a ceramic seal. The pump requires little or no service other than reasonable care. However, a mechanical seal may occasionally become damaged and must be replaced.

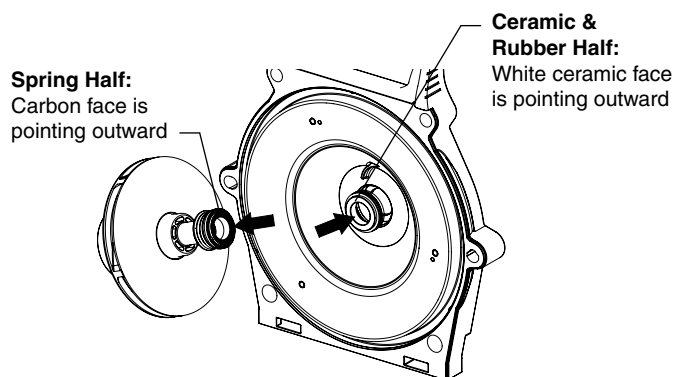

Mechanical Seal

Pump Disassembly

Tools required:

- Adjustable wrench
- Flat-blade screwdriver
- 3/4 inch socket wrench
- 9/16 inch open end wrench
- 9/64 inch Hex key wrench

To remove and repair the motor subassembly, follow the steps below:

1. Turn off the pump circuit breaker at the main panel.
 2. Drain the pump by removing the drain plugs.
 3. Using a 9/16" open end wrench, remove the six (6) nuts that secure the main pump body (strainer pot/volute) to the rear subassembly.
 4. Gently pull the two pump halves apart, removing the rear subassembly.
 5. Remove the three hex head screws holding the diffuser in position with a 9/64 inch hex key wrench.
 6. Using a 3/4" socket wrench, hold the impeller securely in place and remove the impeller lock screw.
- Note:** The impeller screw is a left-handed thread and loosens in a clockwise direction.
7. Remove the screw on the motor rear plastic cover and remove the rear plastic cover.
 8. Using an adjustable wrench to hold the motor shaft, twist the impeller counter-clockwise to remove it from the shaft.
 9. Remove the four (4) nuts from the seal plate to the motor using a 9/16 inch wrench.
 10. Place the seal plate face down on a flat surface and press out the ceramic part of the mechanical seal.
 11. Clean the seal plate, seal housing, and the motor shaft.

Pump illustrated parts view on the next page

Pump Reassembly

1. Install the **spring end** of the mechanical seal onto the impeller shaft. Be sure **black/carbon** face is facing outward.
2. Remount the seal plate to the motor using the four (4) lock washers and four (4) nuts.
3. With the white ceramic face facing outward, press the seal into the seal plate with your thumbs and wipe off the ceramic with a clean cloth. Do not lubricate seal faces.
4. Hand tighten impeller onto the motor shaft.
5. Screw in the impeller reverse lock screw (counter-clockwise to tighten).
6. Install the rear plastic cover on the back of the motor.
7. Remount the diffuser onto the seal plate. Make sure the plastic pins and holding screw inserts are aligned (see "TOP" indicator).
8. Assemble the motor subassembly to the housing. Do not tighten the nuts and washers until all four (4) motor bolts are in place. Using a torque wrench, install and tighten the four nuts to a torque value of 100 in-lbs (maximum). Do not overtighten the nuts.
9. Fill the pump with water.
10. Reinstall the pump lid and locking ring; see Maintenance on page 4.
11. Reprime the system. Refer to page 3 for priming instructions.

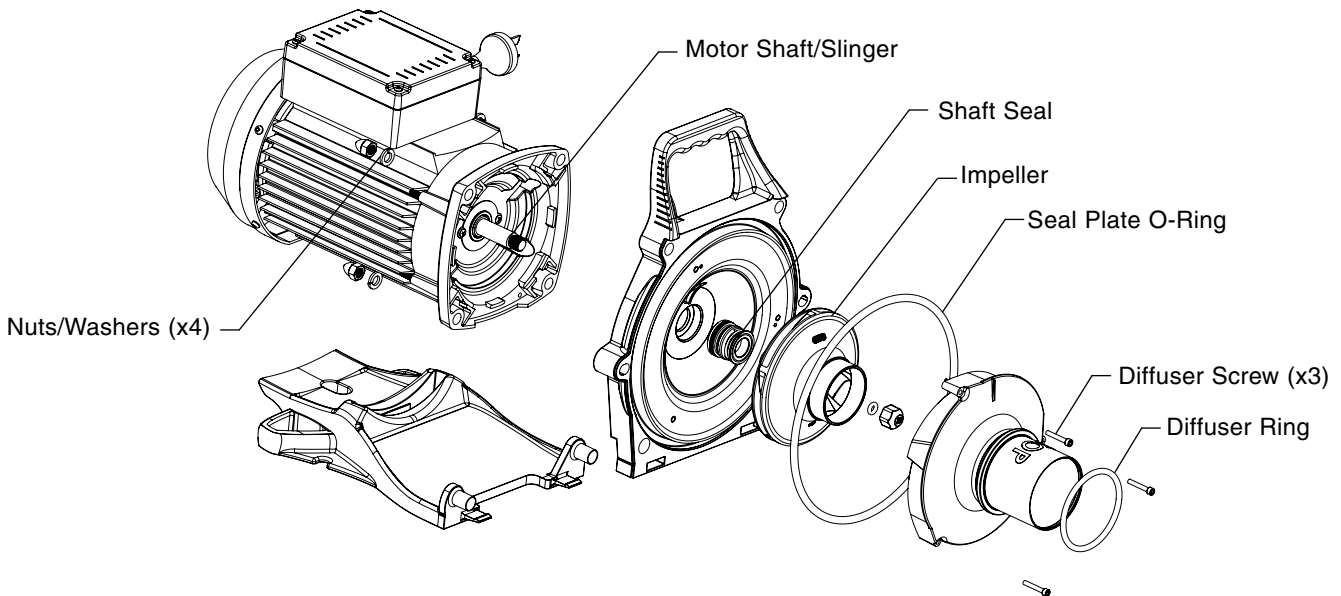

Pump Illustrated Parts View

TROUBLESHOOTING

⚠ WARNING



RISK OF ELECTRICAL SHOCK OR ELECTROCUTION.

Improperly installation will create an electrical hazard which could result in death or serious injury to pool users, installers, or others due to electrical shock, and may also cause damage to property.

1. If you are not familiar with your pool filtering system and/or heater:
 - a. **Do NOT** attempt to adjust or service without consulting your dealer, or a qualified pool technician.
 - b. Read the entire Installation & User's Guide before attempting to use, service or adjust the pool filtering system or heater.
2. **Switch OFF power to the pump before attempting to service or repair.**

Problem	Corrective Action
Pump will not prime	<p>Check suction piping and valve on any suction gate valves.</p> <p>Secure lid on pump strainer pot and be sure lid gasket is in place.</p> <p>Check water level to make sure skimmer is not drawing air.</p> <p>Be sure suction lines, pump strainer, and pump volute are full of water.</p> <p>Be sure valve on suction line is working and open, (some systems do not have valves).</p> <p>Check water level to be sure water is available through skimmer.</p>
Pump gasket defective	Replace gasket.
Reduced capacity and/or head Air pockets or leaks in suction line Pump will not prime — too much air	<p>Check suction piping and valve on any valve suction gate valves.</p> <p>Secure lid on pump strainer pot and make sure lid gasket is in place.</p> <p>Check water level to make sure skimmer is not drawing air.</p> <p>Clean pump strainer pot.</p> <p>Check to see if impeller or diffuser are clogged.</p>
Clogged Impeller	<p>Switch OFF electrical power at the house circuit breakers to the pump.</p> <p>Remove the nuts that secure the volute to the seal plate.</p> <p>Slide the motor and seal plate away from the volute.</p> <p>Clean debris from impeller.</p> <p>If debris cannot be removed, complete the following steps.</p> <ol style="list-style-type: none"> (1) Remove impeller reverse screw and O-ring. (2) Remove, clean and reinstall impeller. (3) Reinstall anti-spin bolt. <p>Reinstall diffuser and O-Ring.</p> <p>Reinstall motor and seal plate into volute.</p> <p>Reinstall hardware around seal plate and volute and tighten securely.</p> <p>Clean suction trap.</p>

REPLACEMENT PARTS

WhisperFloXF™ High Performance Pump Parts List

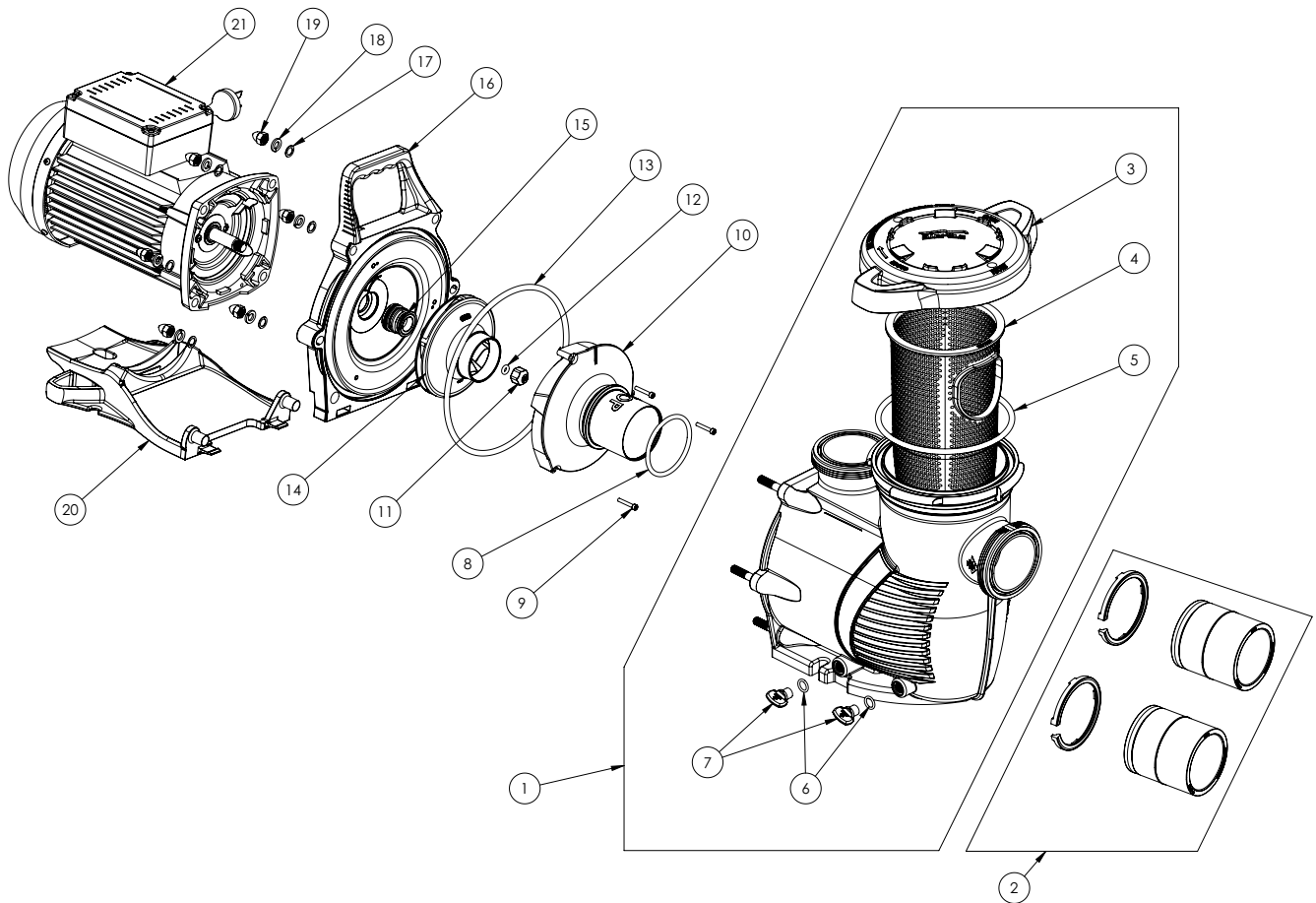

Item #	Description	QTY.	P/N
1	PUMP CASING ASSEMBLY	1	401000
2	BARREL UNION KIT	1	410020
3	LID/LOCKING RING	1	401006
4	BASKET	1	400007z
5	O-RING LID	1	35505-1440
6	O-RING DRAIN PLUG	2	192115
7	DRAIN PLUG	2	357161
8	O-RING DIFFUSER	1	See Diffuser Kit
9	SCREW DIFFUSER	3	
10	DIFFUSER	1	
	DIFFUSER KIT (Includes items 8, 9x3 & 10)	1	
11	SCREW IMPELLER LOCKING	1	See Impeller Kit
12	O-RING IMPELLER LOCKING SCREW	1	
13	O-RING SEAL PLATE	1	351446

Item #	Description	QTY.	P/N
14	IMPELLER	1	See Impeller Kit
	IMPELLER KIT (Includes items 11, 12 & 14)	1	801293
15	MECHANICAL SEAL	1	37400-0028s
16	SEAL PLATE	1	410020
17	WASHER FLAT	6	See Pump Fasteners Kit
18	WASHER SPLIT	10	
19	NUT ACORN	10	
	PUMP FASTENERS KIT (Includes items 17, 18 & 19) x6	1	801294
20	MOTOR BASE	1	401004z
21	MOTOR	1	801482 (405694)

Pump Dimensions

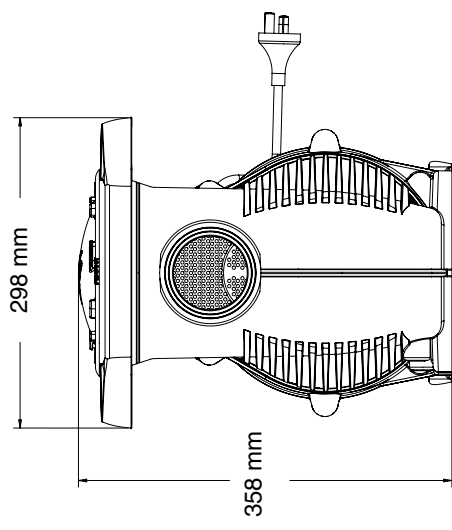
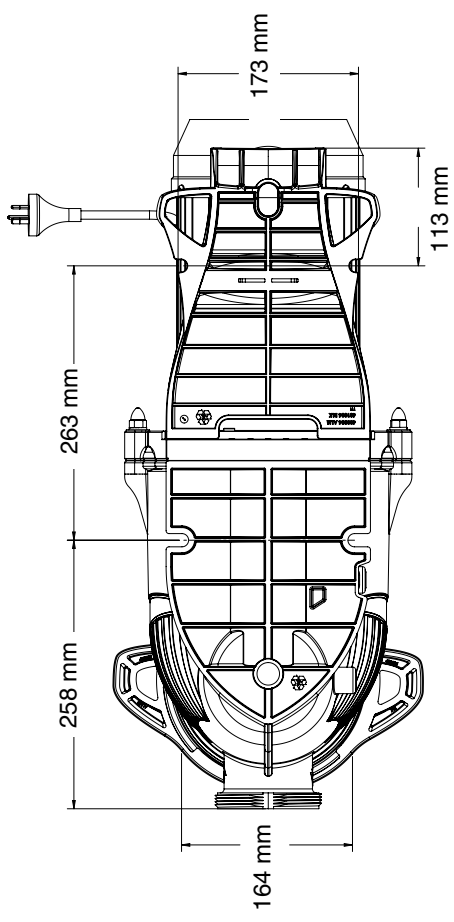
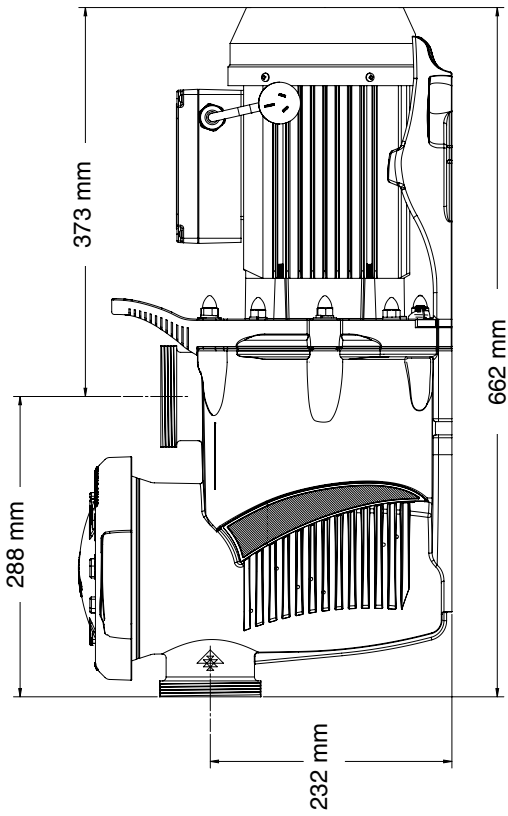
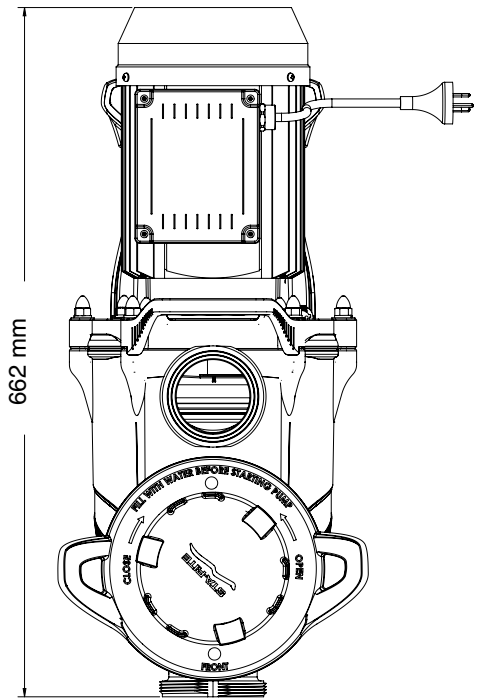

Pump Performance Curves

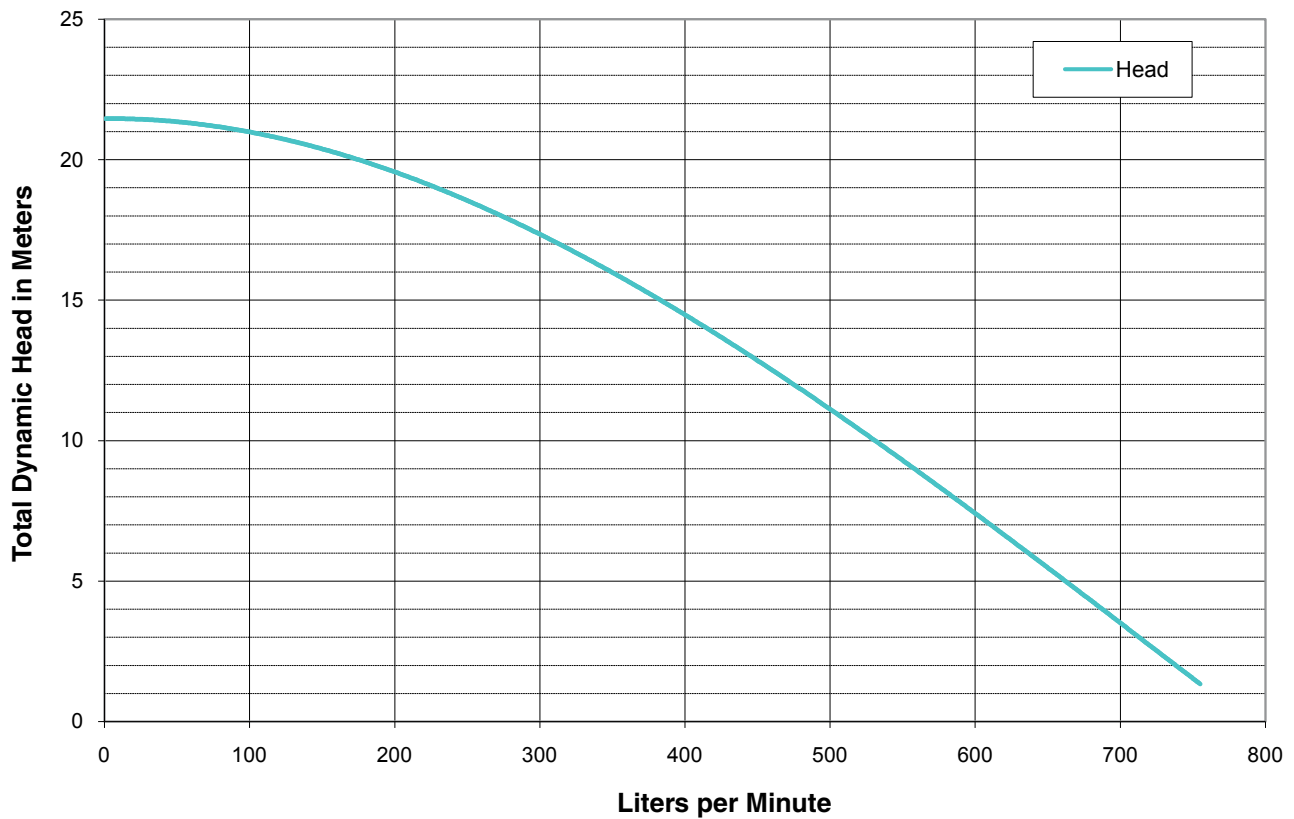

Note: This chart is valid for 50Hz, 2 pole speed and positive pressure.



Rainbow Pool Products

PO Box 2388, Mansfield Qld 4122

Telephone STD 61-7-3849 5385

Facsimile STD 61-7-3849 5384

Email: info@rainbowpoolproducts.com.au

Web: www.rainbowpoolproducts.com.au