

## MODEL 3652607 FPI VALVE ACTUATOR

Suitable for Pool / SPA Equipment Applications

ELECTRICAL RATINGS: 24 Volts, 50 Hz, 0.65 Amps.

TO BE CONNECTED TO A CLASS 2 CIRCUIT ONLY.

### DANGER! To Reduce the Risk of Injury:

...do not permit small children to operate the control or use the Pool/Spa unless they are closely supervised at all times.

...test GROUND FAULT protection regularly. If it fails to reset, DO NOT USE THE POOL or SPA!

Contact a qualified service technician.

...always disconnect electricity before servicing this Control or the equipment connected to it.

**READ, FOLLOW & SAVE THIS INSTRUCTION MANUAL**

## GENERAL INFORMATION

Valve Actuators are an important part of pool/spa automation. They are used for changing the water flow as required by a pre-set program or a remote manual control.

The valve actuator will automate Waterco FPI valves, but is also compatible with most 2 and 3 way diverter valves for pools, spas and water features on the market.

The FPI valve actuator is designed to operate the following Waterco valves:

2 way valve actuated type (4 bar) 50/65 mm.

3 way valve actuated type (4 bar) 50/65 mm.

Additionally, the FPI valve actuator offers the opportunity to be retro-fitted into most existing pool and spa control systems. They can be mounted in four different positions and feature a three-way toggle switch for ease of synchronisation.



## INSTALLATION

### Mounting Options

1. **Standard Plumbing** of a three-port valve is the port B (middle) being the incoming (common) port and A and C ports are the outlet ports (See figure 1).

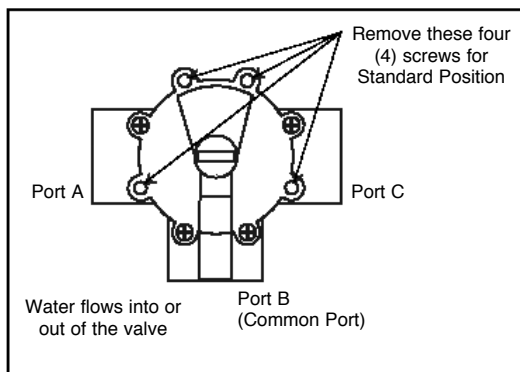

Figure 1. Standard Plumbing.

2. **Standard Actuator Mounting** position is when the main body of the Actuator is over port B (See figure 2).

**NOTE:** If the valve is plumbed as in Figure 1 and the Actuator is mounted as in Figure 2 below, the factory setting of Actuator cams need no adjustment.

3. The Actuator can be mounted on top of a valve in four different positions (See figure 3). Depending on the plumbing of the valve and mounting position of the Actuator, the cams inside the Actuator have to be reset.

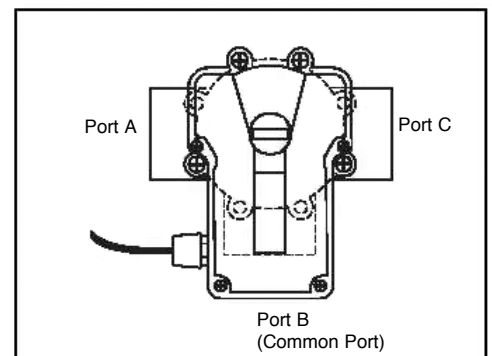

Figure 2. Standard Mounting.

# INSTALLATION

## Mounting Actuator on Top of Valve

1. Unscrew hold-down knob and remove handle from valve shaft. Save knob and handle for later use.
2. Depending on mounting position selected, (See figure 3), remove (4) Philip head screws from valve body. (See figure 1).
3. Turn Actuator over and note that one of the four teeth of the output drive is slightly smaller. Place Actuator over the valve shaft such that the small tooth engages with the small slot in the valve shaft. (See figure 4).
4. Rotate the Actuator, engaged with the valve shaft until Actuator posts line up with the four holes (See step 2 above) in valve body.
5. Attach Actuator to valve, using the four long stainless steel screws - furnished.
6. Reassemble handle to Actuator shaft using the hold-down knob set aside in step 1.
7. Connect power supply cord to a CLASS 2 CIRCUIT ONLY, rated 24V nominal, 4A or 100VA maximum.

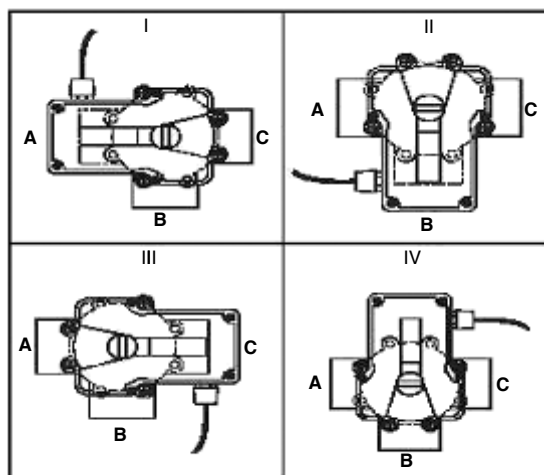

Figure 3. Mounting Positions.

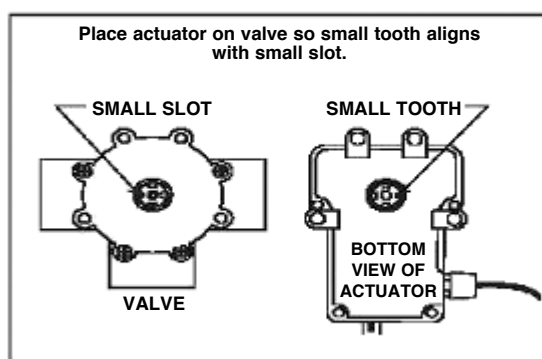

Figure 4. Actuator Mounting.

## Resetting The Cams

**NOTE:** Before resetting cams, read instructions on page 3. Always rotate the actuator shaft to “0” mark on each cam.

### Cam Setting Chart

Actuator Position	Port, Water Enters/Exits Valve (Common Port)	Cam Setting		Port, Water Enters/Exits Valve	
		Top Cam	Bottom Cam	Port	or Port
I*	A	90	180	B	C
I	B	90	270	A	C
I	C	180	90	A	B
II*	A	180	90	B	C
II**	B	0	0	A	C
II	C	90	180	A	B
III*	A	90	180	B	C
III	B	270	90	A	C
III	C	0	270	A	B
IV*	A	0	270	B	C
IV	B	180	180	A	C
IV	C	270	0	A	B

\*Two Port Valve Settings

\*\*Standard Position

# INSTALLATION

## Resetting the Cams

**NOTE: Refer back to Mounting Options on page 1, standard plumbed and mounted valves and Actuators require no cam adjustments. Otherwise, follow instructions below.**

1. Find the mounting position of the Actuator in Figure 3, Page 2.
2. Determine the COMMON and EXIT port(s) of the valve.
3. Refer to table on page 2, find the proper cam settings.
4. Remove four screws and Actuator lid in order to gain access to cam/motor compartment. (See figure 5)
5. Push down and rotate Actuator shaft so that the 0 degree mark lines up with arrow on switch housing. (Bottom cam should now also line up with the arrow. See figure 6.)
6. Reset cams, as defined earlier in Step 3 by loosening the locking nut 1/4 turn counter clockwise and line up specified marking on cams with arrows on switch housings (See figure 6.)
7. Retighten the locking nut. Check cam settings and tightness of shaft assembly.
8. Power up Actuator(s) and check valve rotation and stop positions. Make adjustments if necessary. Refer to "Synchronisation" section below and Trouble Shooting on page 6 if problems develop.
9. Replace lid, make sure screws are tight and the assembly is watertight. Install handle and test operation.

## Synchronisation

Out of sync means: the Actuator is rotating in the wrong direction in respect to its controller or another Actuator. In order to synchronise the system, connect Actuator(s) to its/their controller and observe its/their function. If an Actuator is out of sync, flip the 3-position switch at rear of Actuator to extreme opposite position. An example of how actuators can be out of synchronisation is explained below.

Figure 7 on the right represents the valves and actuators for a pool/spa combination. The valve on the left (spa on left and pool on right) is plumbed just the opposite as the one on the right (pool on left and spa on right). If the actuators are now activated one will turn to spa while the other is turning to pool. Changing the cam settings within the actuator will not correct this problem. To synchronise the actuators, flip the toggle switch at the rear of the actuator (which is out of sync) to the extreme opposite position. (See figure 8. Note: center position is OFF).

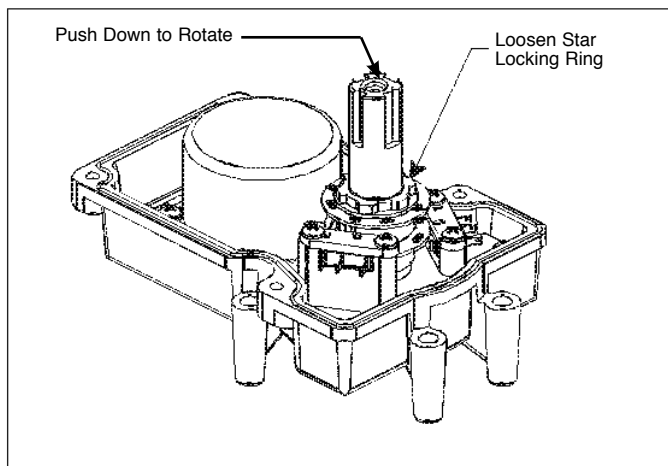

Figure 5. Cam Adjustment.

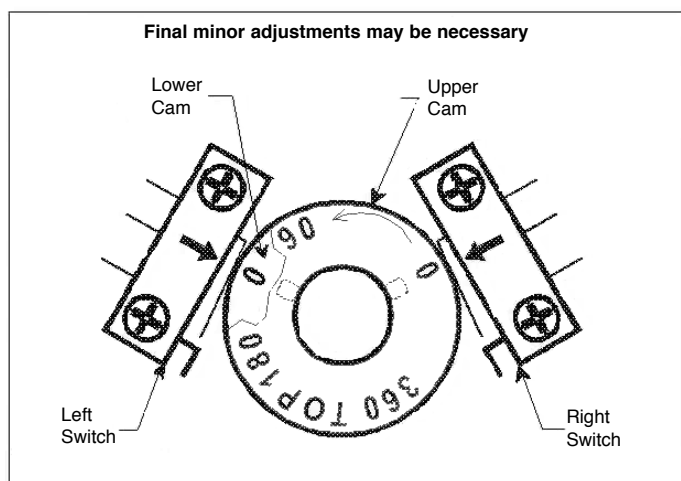

Figure 6. Cams.

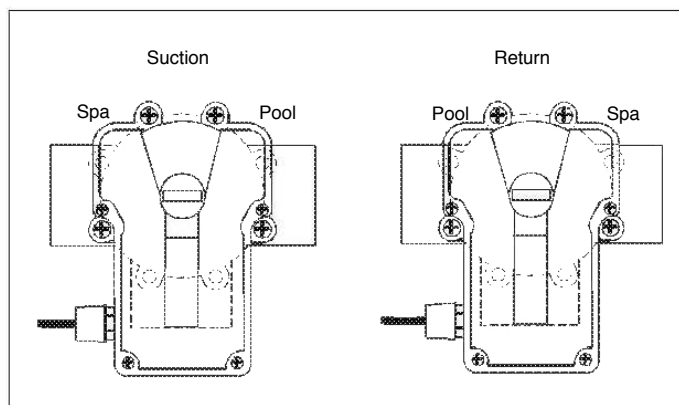

Figure 7. Synchronisation, Example.

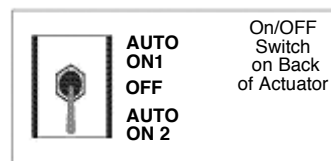

Figure 8. Synchronisation, Toggle.

# OPERATION

## Manual Operation

During the normal operating season of a pool/spa combination, there are times when the valves need to be rotated manually, such as draining or filling the pool or spa.

There are two ways to rotate the valves independent from the controller, either electrically or manually. If the system is operational, the electrical method is recommended. If no power is available, the valves can be rotated manually.

## Manual Operation With Power

1. Move toggle switch at the rear of the Actuator from position 1 to position 2 (See figure 8) or vice versa until desired rotation is reached. Move toggle switch to center position to stop rotation of valve diverter.
2. Return toggle switch to its original AUTO position after service.

## Manual Operation Without Power

**Note: Turn filter pump OFF before attempting to rotate Actuator shaft.**

1. Move toggle switch at rear of Actuator to center (OFF) position.
2. Loosen the hand-locking knob (4) four full turns.
3. Press firmly down on the locking knob in order to disengage the Actuator gear train from valve shaft. Now turn handle to rotate valve diverter to any position desired.
4. After service, the actuator must be returned to the operating (drive) condition by pulling up on the handle while turning it gently back and forth.
5. Tighten the locking knob on top of the handle and return toggle switch back to its original AUTO position (See figure 8).

# MAINTENANCE

This Valve Actuator needs periodic service and depending on the type of valve it is connected to, it may also need lubrication. The valve requiring lubrication comes with a grease cap. Follow manufacturers instructions for servicing such valves. Remember, a poorly maintained valve will lead to early failure of the Actuator.

## Servicing the Actuator

The gear train of the Actuator is permanently lubricated and requires no further service. The seals however need periodic attention. There are three seals that need to be greased once a year. A lip seal is located under the Actuator, where the shaft exits the lower housing and there are two ring seals in the lid, where the shaft exits at the top. To lubricate these seals, use only silicon base lubricant, suitable for the purpose (See figure 9).

1. Turn power OFF to Actuator. (Move toggle switch at rear of Actuator to CENTER position).
2. Loosen locking knob 4 to 6 turns.
3. Press down on locking knob and force the actuator shaft into manual state.
4. Using a small brush, apply a small amount of silicon lubricant around the now exposed portion of the shaft, between the bottom of Actuator and top of valve.
5. Turn handle around once or twice to spread lubricant evenly.
6. Pull upon handle and make sure the gears are now engaged and the Actuator is in AUTO state.
7. Remove locking nut and handle.
8. Apply a small amount of lubricant around the shaft, right where it exits the lid. (The two ring seals are embedded in the protrusion of the lid.)
9. Reinstall handle and place toggle switch to its original AUTO position.

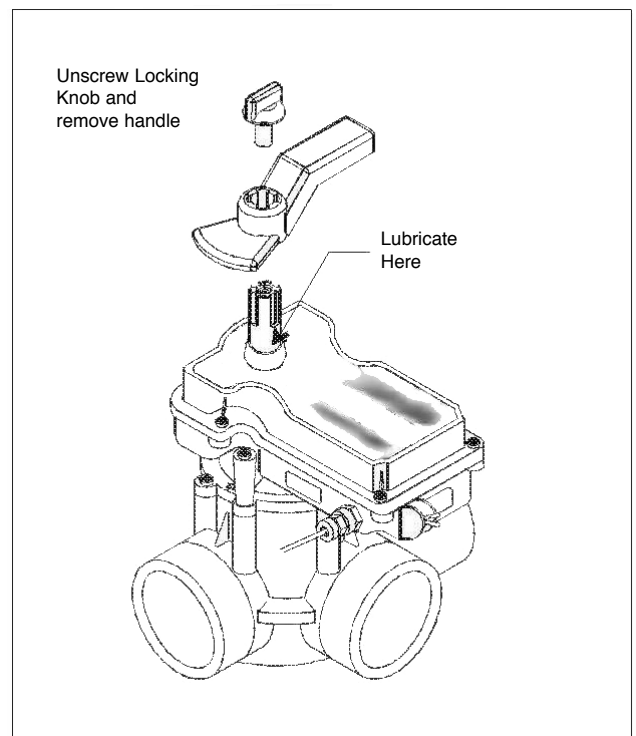
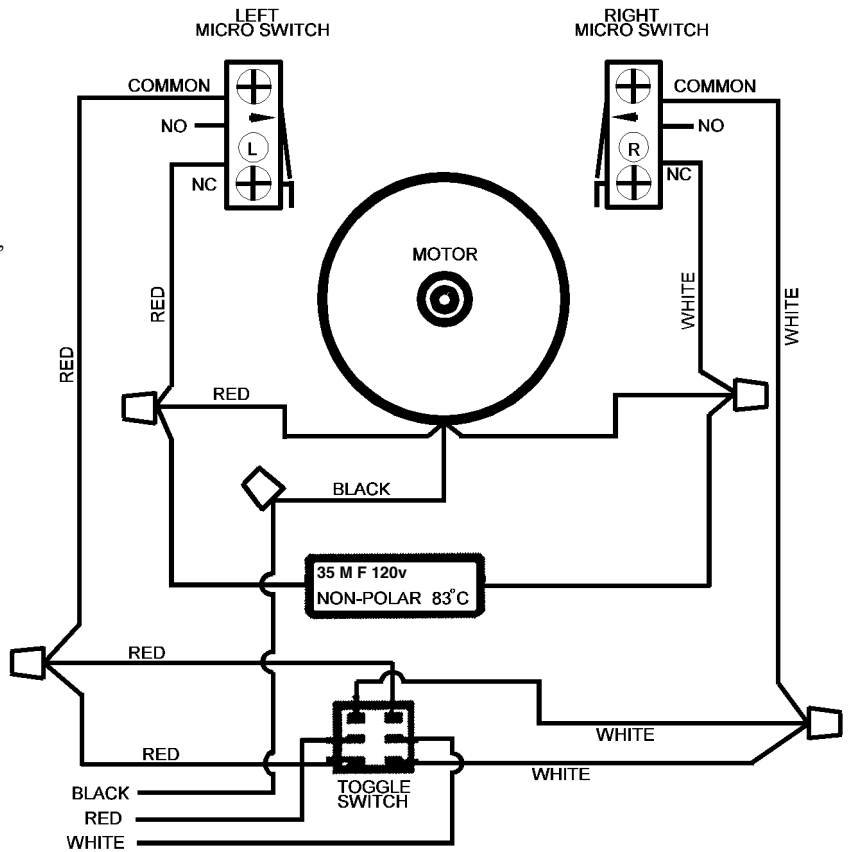

Figure 9. Maintenance.

# TECHNICAL INFORMATION

## SPECIFICATIONS

Voltage: 24 Volts AC  
 Amps: 0.65 Amps  
 Torque: 250 inch pounds  
 (288 kilograms force centimeter)  
 Size: L 7.12" (18.2 cm), H 4.50" (11.5 cm),  
 W 4.77" (12.2 cm)  
 Material: Housing - Noryl; Gears - Steel  
 Grease: MoS2 Lubricant  
 Cord length: 15' (457.2 cm)  
 Rated: Outdoor use



WIRING DIAGRAM

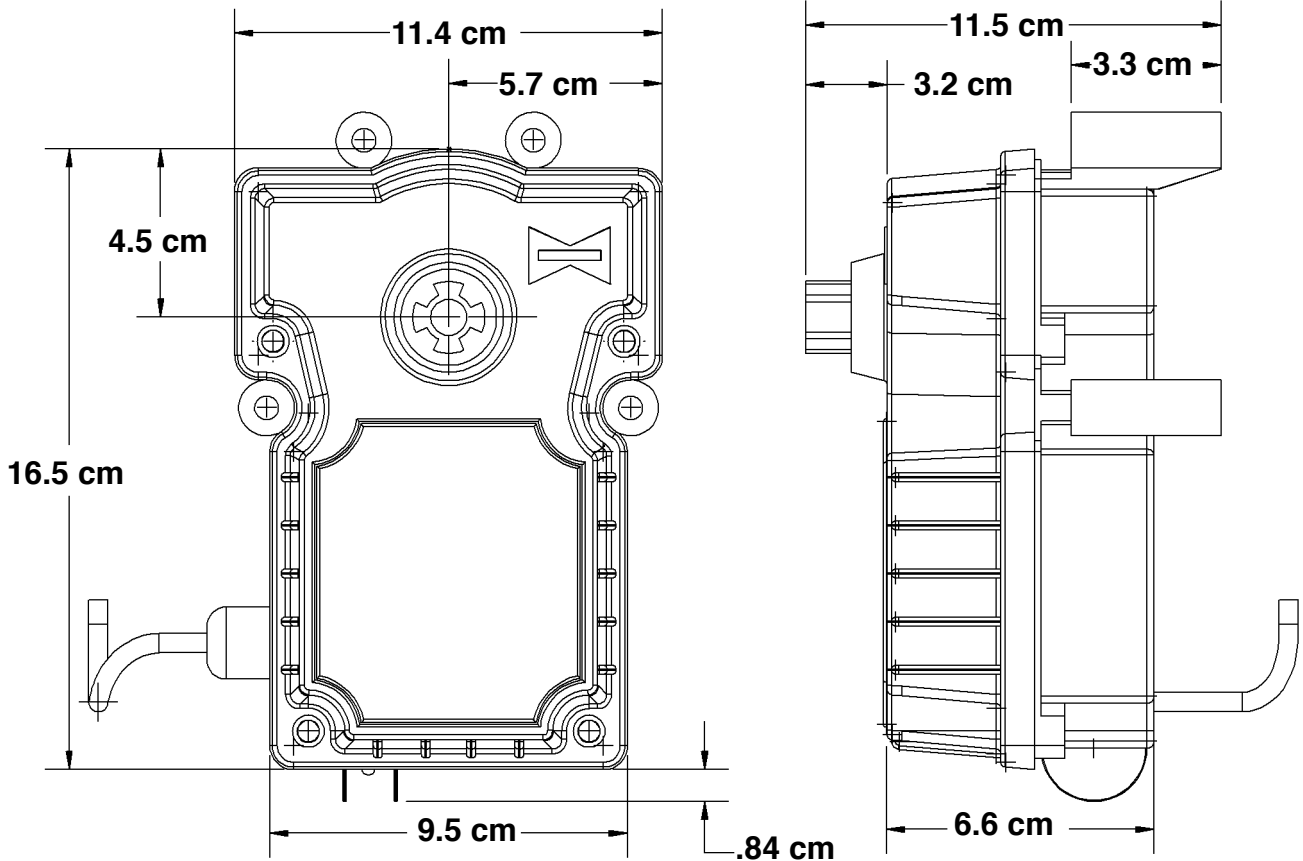

# TROUBLE SHOOTING

<u>Problem</u>	<u>Cause</u>	<u>Solution</u>
1. Actuator handle oscillates.	<ul style="list-style-type: none"> <li>a. Lack of valve seal lubrication.</li> <li>b. Obstruction in valve body.</li> </ul>	Lubricate valve. Remove actuator and valve lid and inspect.
2. Actuator motor works but the valve diverter does not turn.	<ul style="list-style-type: none"> <li>a. Broken actuator shaft.</li> <li>b. Broken valve diverter.</li> <li>c. Actuator is in manual position.</li> <li>d. Actuator gear train is damaged.</li> </ul>	Replace actuator.  Replace valve diverter. Pull up on the handle white rotating counterclockwise. Replace Actuator.
3. Actuator motor does not turn.	<ul style="list-style-type: none"> <li>a. No power to the actuator.</li> <li>b. Toggle switch is in OFF position.</li> <li>c. Motor has failed.</li> <li>d. Failed or broken switch.</li> <li>e. Both cams in contact with their switches.</li> </ul>	Check voltage between black (common) and red then white wires. Move toggle switch to AUTO position 1 or 2 as needed. Replace actuator. Replace switch. Check cam setting.
4. Actuator rotates in one direction but not back again.	<ul style="list-style-type: none"> <li>a. Broken or damaged switch.</li> <li>b. Bad connection(s).</li> <li>c. Bad control relay switch.</li> <li>d. Broken wire.</li> </ul>	Replace switch.  Check all connections. At the power source check the operation of the control relay or switch. Check red and white wires.
5. Water inside Actuator.	<ul style="list-style-type: none"> <li>a. Damaged seals.</li> </ul>	Replace top lid and grease seals.



## Rainbow Pool Products

PO Box 2388, Mansfield Qld 4122

Telephone STD 61-7-3849 5385

Facsimile STD 61-7-3849 5384

Email: [info@rainbowpoolproducts.com.au](mailto:info@rainbowpoolproducts.com.au)

Web: [www.rainbowpoolproducts.com.au](http://www.rainbowpoolproducts.com.au)