



# Hydrostar MKIII Pumps

Commercial high performance pumps



Built with an innovative quarter lid & lock ring and extra large strainer basket, the Hydrostar is ideal for large domestic and commercial sized swimming pools.

- 6 litre strainer basket.

## HYDROSTAR MKIII PUMPS

Part Number	Product Description	Nominal Size
240440033	Hydrostar 400 MKIII	4.0hp
240450033	Hydrostar 500 MKIII	5.0hp
240460033	Hydrostar 600 MKIII	6.0hp
240470033	Hydrostar 700 MKIII	7.0hp

### Sea water mechanical seal

63401625 Sea water mechanical seal

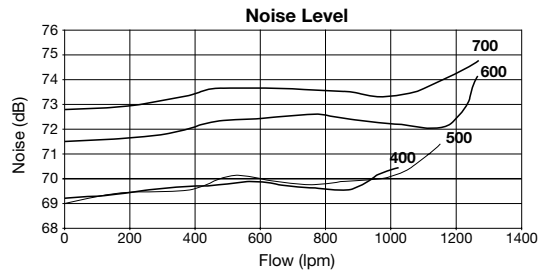
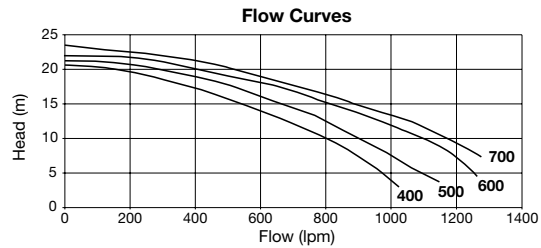

## Specifications

Model	Nominal Power (hp)	Input Power (kW)	Amps/Phase	Weight (kg)	Total Length (mm)	Motor Frame	Inlet/Outlet
Hydrostar 400MKIII	4.0	2.92	5.2	44.0	939	100	80mm ports x / 80mm unions
Hydrostar 500MKIII	5.0	3.16	5.8	44.0	939	100	80mm ports x / 80mm unions
Hydrostar 600MKIII	6.0	4.36	7.0	48.5	939	100	80mm ports x / 80mm unions
Hydrostar 700MKIII	7.0	5.18	8.2	48.5	939	112	80mm ports x / 80mm unions

Phase	Volts	Cycle	RPM	Pump Rating
3	380 - 420	50	2900	IP55

## Dimension

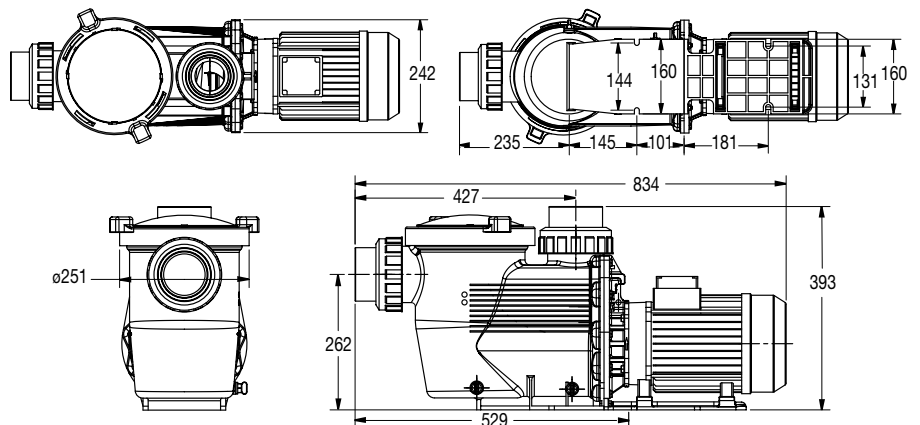

## Warranty

Waterco commercial pumps are covered by a comprehensive 1 year warranty for commercial installations.