

# MULTI CYCLONE 70XL

## CENTRIFUGAL WATER FILTRATION

A revolution in pool filtration, MultiCyclone 70XL is a brilliant per-filtration device that works on the basis of centrifugal water filtration and is designed with no moving parts and no filter media to clean or replace.

- ① **Minimises filter maintenance and saves water**
- ② **No filter media to clean or replace**
- ③ **Maximum flow rate of 90m<sup>3</sup> / hr**
- ④ **Compact size and ease of installation**
- ⑤ **Suitable for new and existing commercial installations**



### Rainbow Pool Products

PO Box 2388, Mansfield Qld 4122

Telephone STD 61-7-3849 5385

Facsimile STD 61-7-3849 5384

Email: [info@rainbowpoolproducts.com.au](mailto:info@rainbowpoolproducts.com.au)

Web: [www.rainbowpoolproducts.com.au](http://www.rainbowpoolproducts.com.au)



**WATERCO**  
water, the liquid of life



## Multi-award winning

Waterco has developed a revolutionary centrifugal filtration system that is both economical and eco-friendly.

Since launching in 2008, Waterco's MultiCyclone technology has continued to impress the world with its innovative design, which has earned it 11 local and international awards, including 2007 Piscina Barcelona Sustainability Award, Splash Environmental product of the year 2010, Best Product Award at SPATEX UK in 2011 and 2012, and the Design Master Green Award at India's WAVES International Pool, Spa and Bath Expo.



The MultiCyclone 70XL is an evolution of Waterco's MultiCyclone technology. Waterco has specially created a commercial version by increasing its number of hydrocyclones to cater for the higher flow rates and redesigned to cope with the demanding requirements of commercial installations.

The MultiCyclone 70XL has been specially created to handle larger water capacities for commercial and industrial applications.

## Ease filter workload

An Australian innovation, MultiCyclone 70XL pre-filters up to 80% of the filter's incoming dirt load prior to the main filter, reducing the load on the filter and therefore reducing the frequency of filter maintenance by up to 80% and saving backwash water.

As the MultiCyclone 70XL intercepts more and more sediment, the flow rate remains unchanged, improving pool water circulation.



## Centrifugal water filtration

MultiCyclone 70XL works on the basis of centrifugal water filtration and is designed with no moving parts and no filter media to clean or replace.

UV and corrosion proof

Glass filled thermoplastic housing

70 hydrocyclones configured for optimal filtration

Sediment chamber

Sediment inspection port

Purge valve for ease of maintenance

- i. Incoming water enters 70 hydro cyclones tangentially, generating a strong centrifugal effect.
- ii. The sediment is spun out to the hydro cyclone's wall, and then spirals down to the sediment chamber\*.
- iii. The filtered water migrates towards the centre of the hydro cyclone where the flow reverses and spirals upwards through the outlet.
- iv. Accumulation of sediment can be visibly monitored through the MultiCyclone's inspection ports
- v. The MultiCyclone is easily cleaned by opening its purge valve. Only 300 litres of water is discharged to cleanse the MultiCyclone.

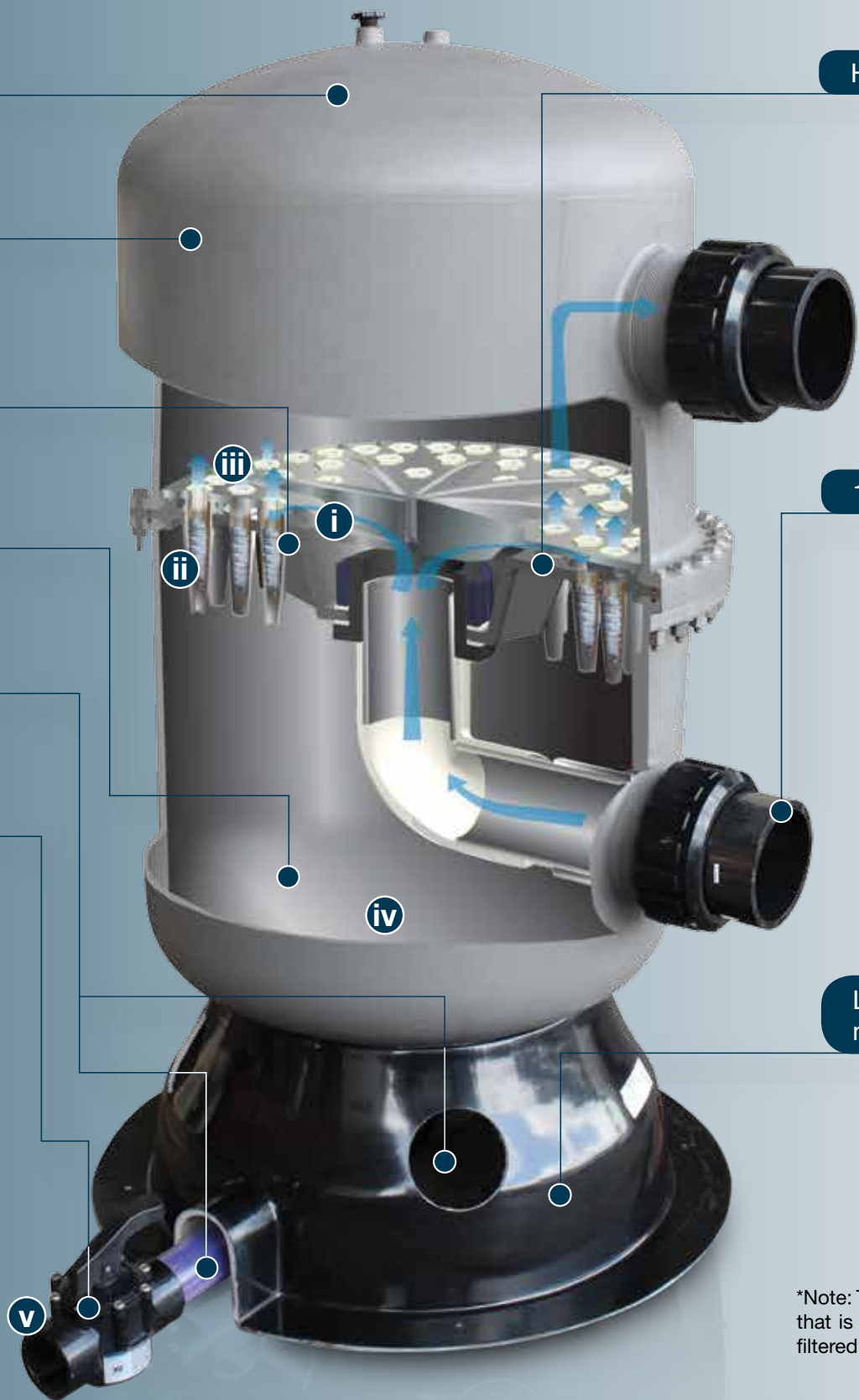

Hydraulically efficient internals

100mm / 4" quick connect unions

Large filter base for stable floor mounting

\*Note: The MultiCyclone is designed to filter sediment that is heavier than water, floating debris cannot be filtered out by centrifugal filtration.

## MultiCyclone 70XL solution for Seaview Haven Holiday Park

The Seaview Haven Holiday Camp at Weymouth Bay, on England's south coast, is defined by its water facilities, which includes heated indoor and outdoor swimming pools. And when the camp's operators undertook a major refurbishment of the indoor pool in February 2013, the contractor discovered a 'small problem'.

An existing indoor pool was being refurbished and upgraded, but the plant room could not be altered which meant there was insufficient room to add another filter in order to meet the latest PWTAG standards.

The MultiCyclone 70XL is designed specifically for use in commercial pools and given the 90m<sup>3</sup> Seaview Haven pool caters for a large volume of people, the MultiCyclone 70XL was the perfect solution to address the client's space and budget restrictions.

The MultiCyclone 70XL, gives the staff at Seaview Holiday Park a break from the intense maintenance schedule, as the system requires less backwashing than the previous filter.

The MultiCyclone 70XL gave an opportunity to upgrade filtration whilst taking up less plant room space than another filter, and at less cost.



### MultiCyclone 70XL Head Loss Curve

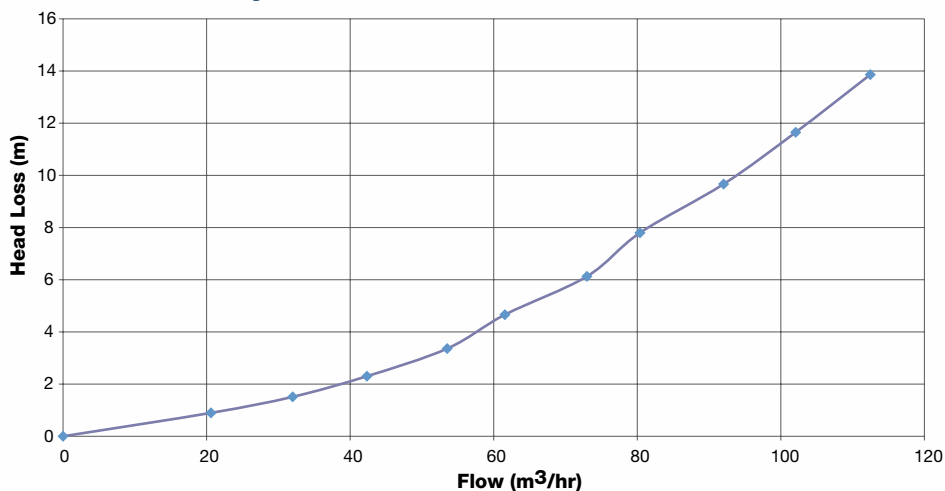

### Dimension

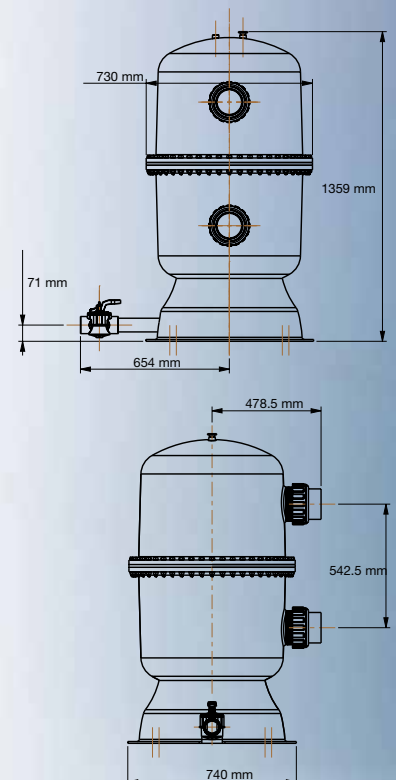

### Technical Specification

Model	Connection Ports	Minimum Flow Rate	Maximum Flow Rate	Pressure Rating
MultiCyclone 70XL	100mm/4" Nominal	36m <sup>3</sup> /hr (158 GPM)	90m <sup>3</sup> /hr (396 GPM)	2.5 Bar (250 kPa)

## Warranty

MultiCyclone XL is covered by a 2 year warranty and a 12 month warranty on labour.