



POLARIS 360

Code	Description
W7520005	Polaris Vac-Sweep® 360
W7520005P	Polaris Vac-Sweep® 360, Positrax®

1 Year Warranty

IMPORTANT INFORMATION

- Always disconnect the Polaris from the pool wall when cleaning or backwashing the pool filter.
- After cleaning or backwashing, let the filtration system run for at least five minutes before re-connecting the Polaris.
- New plumbing lines should be flushed out before installing the Polaris.
- The Polaris should not be used to remove plaster dust in new pools.
- Always remove the Polaris **before swimmers enter the pool.**
- Except when checking the wheel RPM, do not handle the Polaris while it is operating.
- Always remove the Polaris from the pool before chemical shock treatments.

Polaris Vac-Sweep® 360 Limited Warranty

This one year limited warranty is extended to the original consumer purchaser of this Polaris Vac-Sweep 360 Automatic Pool Cleaner manufactured by Polaris Pool Systems, Inc., from date of manufacture of the unit as established by the serial number, or one year from date of purchase with proof of purchase, whichever is later. Polaris warrants this product, including all parts and components thereof, to be free of defects in material and workmanship. Normal replacement items such as bags, tires, sweep hoses or sweep hose scrubbers which have been worn out by use or improper installation are not covered by this warranty. The Polaris 360 frame is warranted for a period of ten years.

This limited warranty does not apply if the failure is caused or contributed to by any of the following: improper handling, improper usage, improper storage, winter freezing, abuse, improper installation, removal of the UWF filter screen, unsuitable application of the unit, improper maintenance, lack of reasonable and necessary maintenance, damage in transit or during installation, or damage from repairs/alterations made or attempted by anyone other than Polaris or one of its Authorized Service Centers.

Authorization to return a unit or part to the plant of manufacture must be obtained from the Polaris Customer Service Department. Check with your dealer for the local procedure before exercising this warranty. If further directions or instructions should be required, contact the Customer Service Department at 1-800-VAC-SWEEP (USA and Canada only) or (760) 599-9600. Be sure to insure the shipment against loss or damage in transit.

This limited warranty is valid only in the United States of America, Canada and Australia, and it does not apply to Polaris Vac-Sweep 360 Automatic Swimming Pool Cleaners sold or installed in any other country. Polaris Vac-Sweep 360 Automatic Pool Cleaners sold in the United Kingdom are warranted for a period of two years from date of invoicing to the first user.

WARNING: USE OF POLARIS 360 IN A VINYL LINER POOL

Certain vinyl liner patterns are particularly susceptible to rapid surface wear or pattern removal caused by objects coming into contact with the vinyl surface, including pool brushes, pool toys, floats, fountains, chlorine dispensers, and automatic pool cleaners. Some vinyl liner patterns can be seriously scratched or abraded simply by rubbing the surface with a pool brush. Ink from the pattern can also rub off during the installation process or when it comes into contact with objects in the pool. Polaris is not responsible for, and the Limited Warranty does not cover, pattern removal, abrasion or markings on vinyl liners.

POLARIS 360 COMPLETE CLEANER

1. All-Purpose Bag
2. Head Float
3. Cleaner Body
4. Sweep Hose
5. Sweep Hose Scrubber
6. Replacement Eyeball
7. Eyeball Regulators
8. Feed Hose
9. Hose Floats
10. Back-up Valve
11. Pressure Tester
12. Quick Disconnect with Universal Wall Fitting

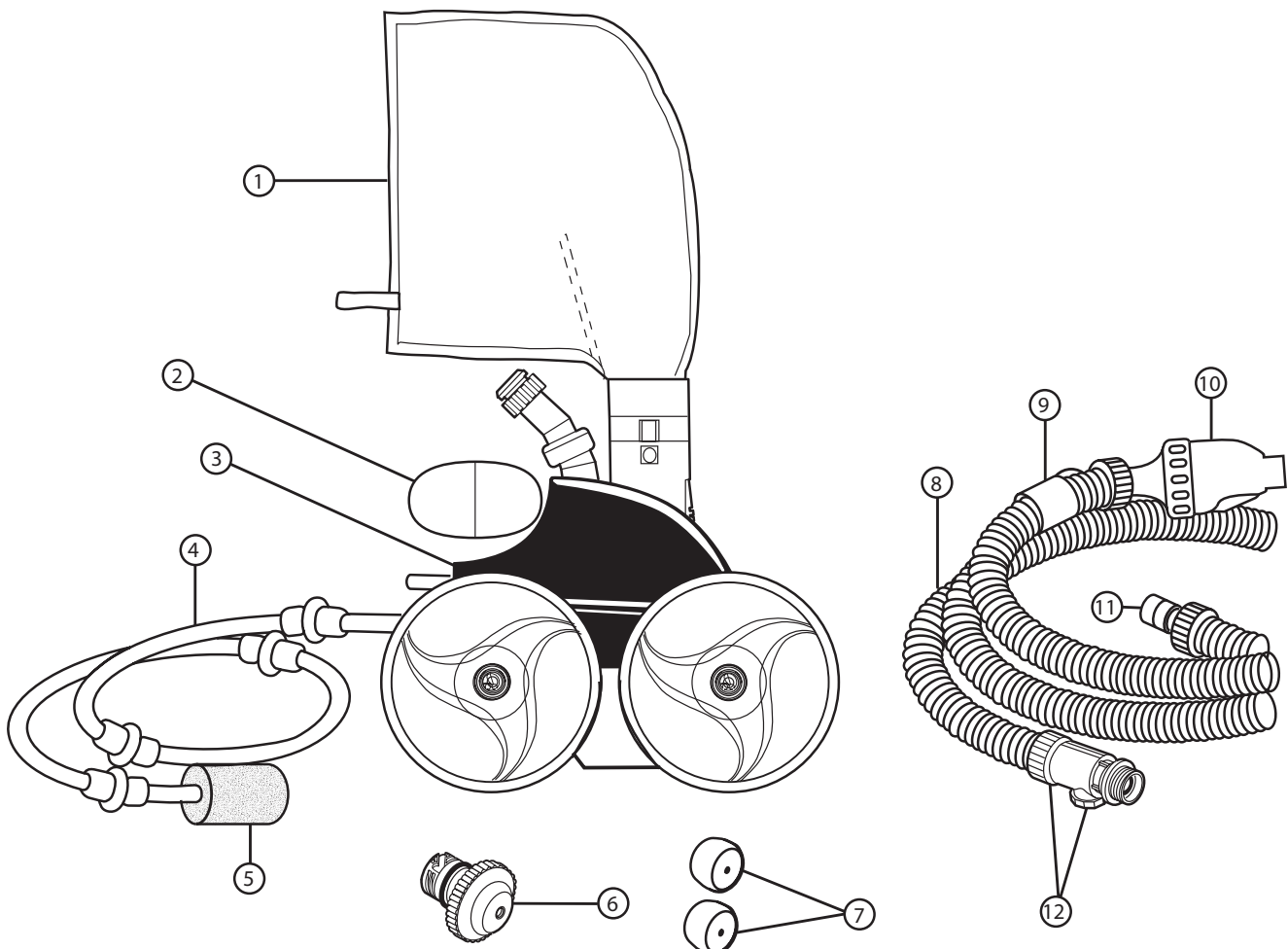

QUICK INSTALLATION INSTRUCTIONS

Four quick steps to install and get maximum performance from the Polaris 360:

- Install the Universal Wall Fitting (UWF) with Quick Disconnect and Eyeball Regulators
- Test and adjust water pressure
- Adjust feed hose to fit pool length
- Check for proper wheel RPM (revolutions per minute)

1. Install the Universal Wall Fitting

Installs in minutes on pools with a dedicated cleaner return line and a threaded 1-1/2" female pipe fitting.

1. Turn on the filtration pump and flush out the plumbing line. Turn pump off.
2. Remove the UWF from the Quick Disconnect and screw it into the return opening.
3. Turn the Quick Disconnect clockwise into the UWF and pull away to secure.

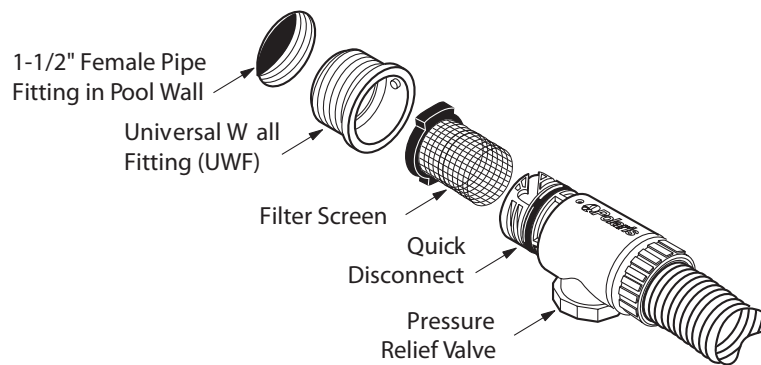

Install Eyeball Regulators

If the pool has more than one return line, install the Eyeball Regulators to ensure the pool's water pressure is high enough to operate the Polaris 360.

Use the Replacement Eyeball with a Quick Disconnect fitting to restore proper water circulation when the Polaris 360 is removed from the pool.

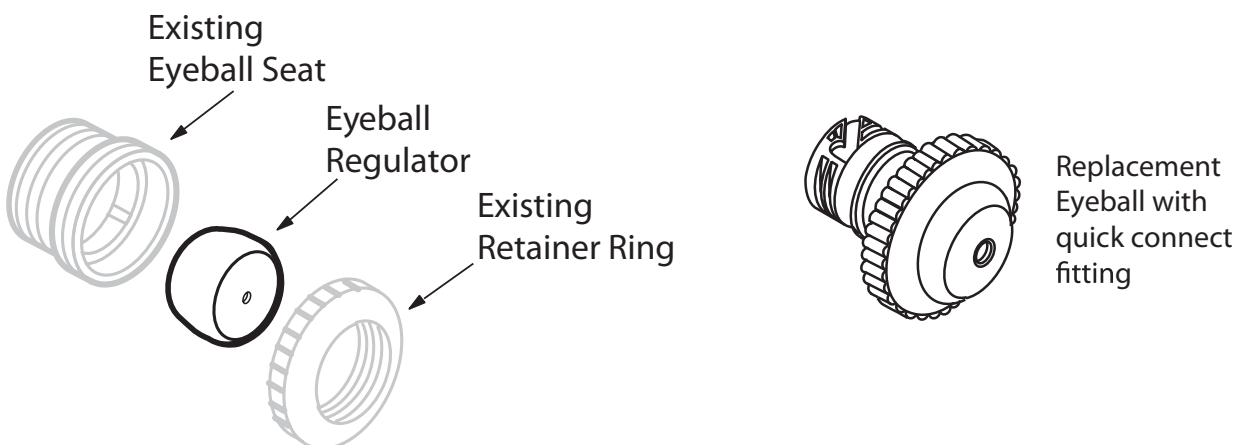

If the Universal Wall Fitting and Eyeball Regulators are successfully installed, SKIP to Step 2. Otherwise, see Installing Other Pool Connections.

Installing Other Pool Connections

If the pool does not have a dedicated return line, the Polaris 360 connects to most common return lines using special adapter kits available for purchase at a participating Polaris dealer.

For pools with plastic-pipe return lines (without pipe threads) that are cut off flush with the pool wall:

If pipe is 1" in diameter, use 1" Stub Pipe Connection Kit (part #9-100-8002)

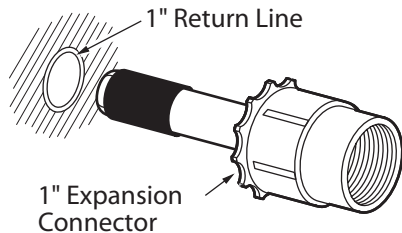

If pipe is 1-1/4" in diameter, order 1" Stub Pipe Connection Kit (part #9-100-8002) and 1-1/4" Sleeve Kit (part #8-841-00).

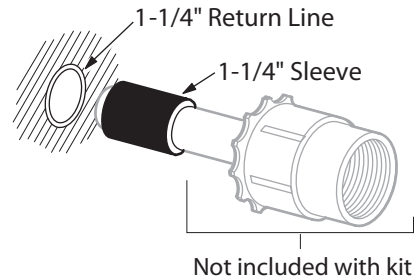

If pipe is 1-1/2" in diameter, use 1-1/2" Stub Pipe Connection Kit (part #9-100-8003).

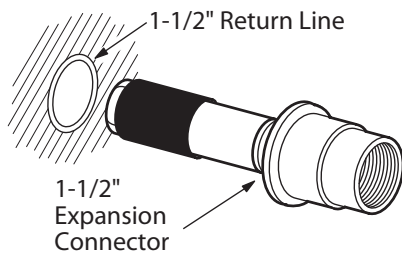

For directional eyeball fittings that do not have a 1-1/2" threaded socket, request the Eyeball Adapter Connection Kit (part #9-100-8005).

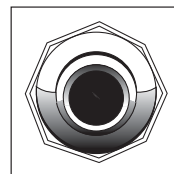

Does current fitting look like this?

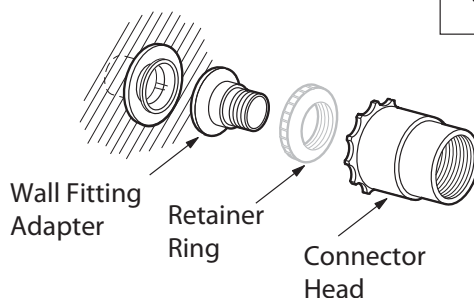

These are the most common, but not all of the possible pool connections.

If the UWF and Eyeball Regulators still cannot be installed on the pool, contact your dealer or Customer Service to determine which parts may be necessary.

Other Connections Requiring Special Fittings

If a spa is connected to the pool filtration equipment, obtain expansion regulators in addition to one of the kits listed above. Contact your dealer or Customer Service to determine which parts may be necessary.

2. Test and Adjust Water Pressure

The Polaris is packaged with a pressure tester installed on the hose. Simply attach the hose to pool wall using the Quick Disconnect fitting. Turn pump on, cover large hole with thumb and confirm that water is released from the Pressure Relief Valve.

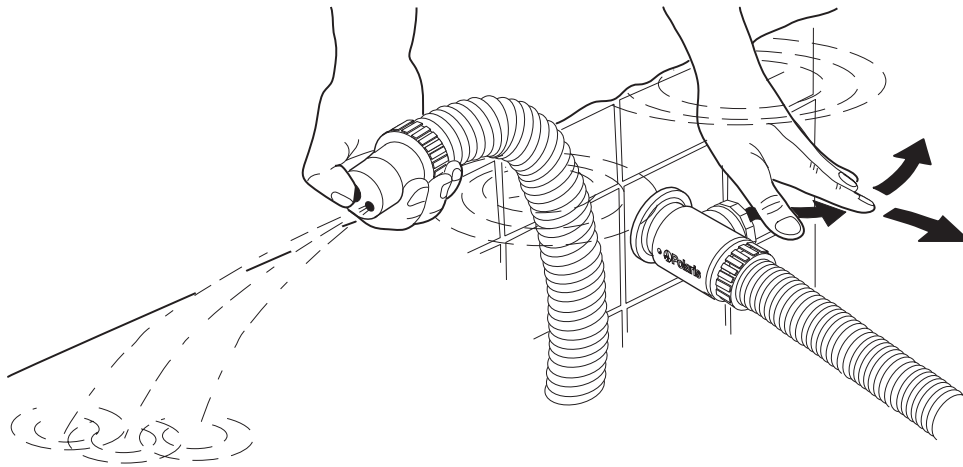

If water does not release from the Pressure Relief Valve, there is insufficient water pressure to operate the Polaris pool cleaner.

- Check the filter screen in the Quick Disconnect for debris which restricts water flow.
- Clean the skimmer, filter and pump basket, clearing debris which restricts water flow.
- Check the hoses, connections and swivels for leaks that cause loss of water pressure.
- If the cleaner is connected to a dedicated return line, adjust the 3-way diverter to increase water flow.

3. Adjust Feed Hose to Fit Pool Length

With the hose connected to the pool wall at the return line, hold feed hose under water and turn on the pool pump. Extend the hose to the farthest point of the pool. The hose end must be within 6" of this point – longer or shorter – as shown by the dotted line.

Hose too long? Cut excess length from first hose section and reconnect hose sections.

Hose too short? Buy an additional hose section and add to first hose section.

After adjusting the hose length, position the three hose floats as indicated by the diagram.

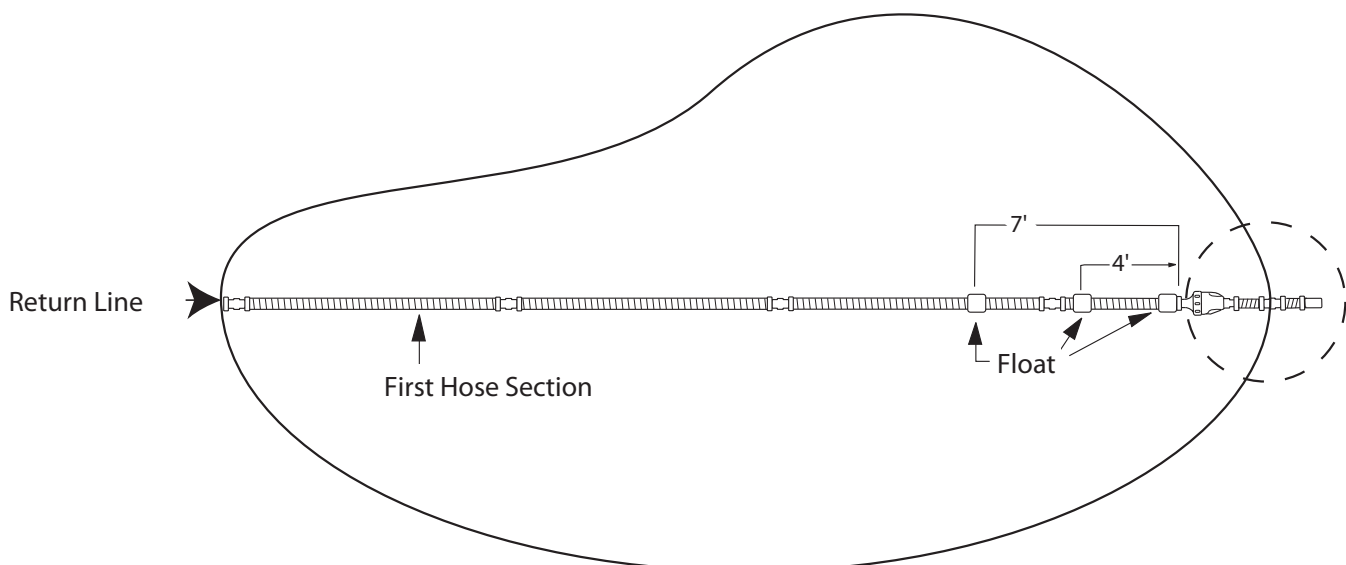

Assemble Cleaner

1. Remove the pressure tester from the hose by unscrewing the hose nut and pulling off hose.
2. Use hose nut from the pressure tester to secure hose to the cleaner body at the feed pipe.
3. The filter bag is packaged in the collar area on the cleaner body. Pull out the bag and snap the bag tie collar onto the feed hose.
4. Push Head Float all the way in, against cleaner body.
5. Place the Polaris into the pool. Turn on the pool filtration pump.

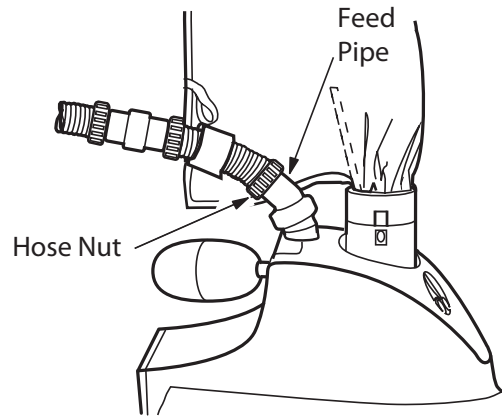

4. Check for Proper Wheel RPM

Before operating the Polaris, check for proper wheel revolutions per minute (RPM). For maximum efficiency, the Polaris should operate between 28 and 32 RPM.

1. Mark the single-wheel side tire.
2. Turn pump on, hold cleaner below water level and count wheel revolutions for 1 minute.
3. Optimum speed should be **between 28 and 32 RPM**.

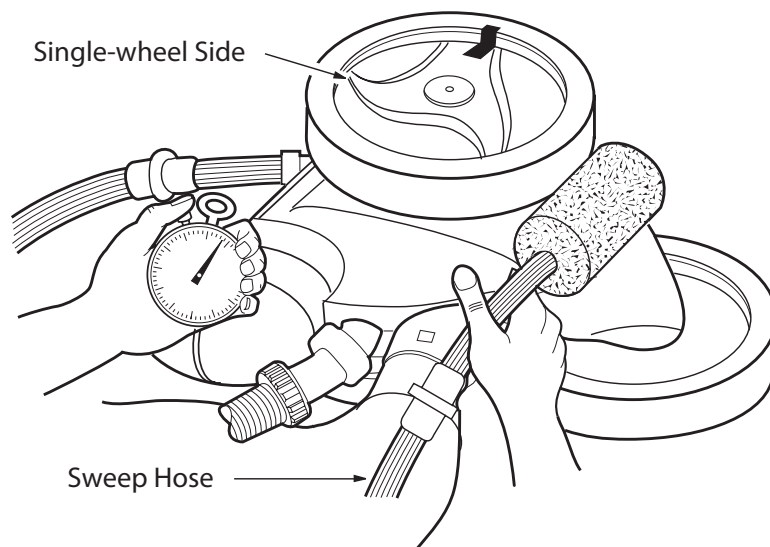

If count is less than 28 RPM:

- Check the filter screen in the Quick Disconnect for debris.
- Clean the skimmer, filter and pump basket.
- Check the hoses, connections and swivels for leaks.
- If the cleaner is connected to a dedicated return line, adjust the 3-way diverter to increase water flow.

If count is more than 32 RPM, unscrew the Pressure Relief Valve until the proper RPM is reached. If an adjustable valve has been installed, adjust the valve to reduce the amount of water flow.

FINE TUNING THE POLARIS CLEANER

When operating correctly, the Polaris vacuums, sweeps and scrubs all surfaces randomly throughout the pool. The climbing ability of the Polaris depends on the pool's shape and water pressure or flow. The Polaris climbs best in pools without sharp angles or curves in the transition from the pool floor to the pool wall.

Approximately every 3-1/2 minutes the Polaris 360 goes into back-up mode. This action pulls the Polaris away from pool obstacles.

Thrust Jet Adjustment

The thrust jet powers the direction of the Polaris. Factory position is eleven o'clock, but depending on the pool, other settings are helpful.

Sweep Hose Adjustment

The sweep hose should move in a gentle sweeping motion.

To decrease the motion of the sweep hose, turn the sweep hose adjustment screw clockwise.

See Troubleshooting for other action adjustments.

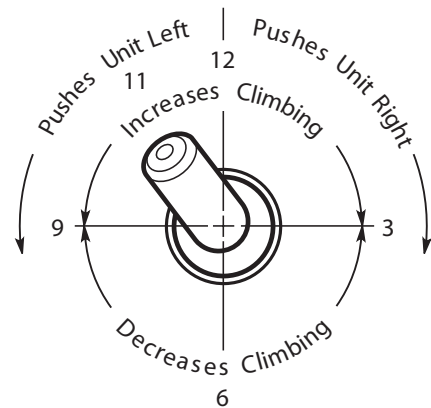

ROUTINE MAINTENANCE

Cleaning the Filter Bag

Detach the bag by releasing the prongs and removing the bag tie collar from the feed hose.

Open the closure and dump out the debris.

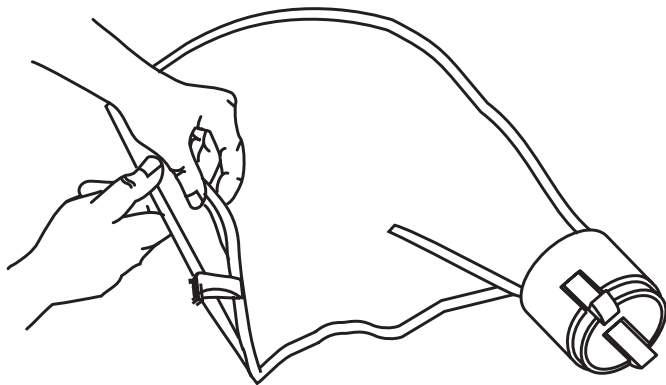

- Whenever possible, empty the filter bag when it is half full, especially if the dirt load is sand.
- It is easier to empty the filter bag when it is dry. Alternate between two filter bags. When one becomes full, remove it and put on the clean bag.

Backwashing the Pool Filter

Always disconnect the Polaris from the pool wall before cleaning or backwashing the pool filter. After cleaning or backwashing, let the filtration system run for at least five minutes to flush out the return lines before re-connecting the Polaris.

Storage and Winterizing

Never store the Polaris in direct sunlight. When storing for the winter, drain out all the water (freeze damage is not covered by the warranty). Remove the UWF from the pool wall by attaching the Quick Disconnect and using pulling pressure to unscrew. In some cases, it may be necessary to use the UWF Removal Tool (part #10-102-00) available from participating Polaris dealers.

TROUBLESHOOTING

If the Polaris cleaner displays the following actions, adjustments may be necessary to restore performance.

Action: Hangs up on steps or other obstacles longer than 3-1/2 minutes.

- Solution:
1. Check the wheel RPM.
 2. Verify the back-up valve is cycling.
 3. Adjust the thrust jet.
 4. Remove unnecessary pool hardware or install a Ladder Guard Kit (order part #G21 from a Polaris dealer).

Action: Polaris is sluggish, running with less power than normal.

- Solution:
1. Check the filter screen in the Quick Disconnect and clean, if necessary.
 2. Clean the skimmer basket, pump basket, and pool filter.
 3. Check all of the hoses, connections, and swivels for leaks that could cause loss of water pressure.
 4. Check the wheel RPM.

Action: Polaris flies around the pool.

- Solution:
1. Check the wheel RPM. If more than 32 RPM, unscrew the pressure relief valve to decrease water flow to cleaner.
 2. Verify the back-up valve is cycling. Hold the valve out of the water and watch the jet. It should come on and go off.
 3. Adjust 3-way diverter to reduce the amount of water flow to the Polaris pool cleaner.

Action: Polaris does not back up.

- Solution:
1. Verify the back-up valve is cycling.
 2. Check the wheel RPM.
 3. If the bag is full, empty it.
 4. If head float has water in it, replace it.
 5. Make sure feed hose is floating.

Action: Polaris only turns in one direction.

- Solution:
1. Adjust the thrust jet.
 2. If the end of the hose that connects to the Polaris has a curve to it, align it with the curve of the feed pipe.
 3. Make sure that the swivel on the feed pipe turns freely.
 4. Ensure feed hose is floating

Action: Feed hose becomes tangled.

- Solution:
1. Remeasure the hose to verify that it is adjusted to the proper length for the pool shape.
 2. With the Polaris operating, check that the swivels in the hose and the hose connections turn freely.
 3. Make sure feed hose is floating.
 4. With the Polaris turned off, spin each of the wheels. All wheels should turn together.

Action: Sweep hose is sucked into the vacuum tube.

- Solution:
1. Make sure the opening at the end of the sweep hose is not blocked by the sweep hose scrubber.
 2. Adjust the sweep hose to a gentle sweeping motion.

Action: Sweep hose sprays too much water out of the pool.

- Solution:
1. Adjust the speed of the sweep hose by tightening the adjustment screw.
 2. Replace the sweep hose scrubber (part #9-100-3105) if it is worn or missing.
 3. Add a sweep hose weight (order part #B2) to keep the sweep hose from spraying.

Action: The cleaner does not clean the entire pool.

- Solution:
1. Check the hose length reaches within 6" of the farthest point of the pool. If not, order a new hose section from your Polaris dealer and add it to the first hose section.
 2. Check thrust jet for 11 o'clock position that optimizes random turning.
 3. While the cleaner is operating, hold it upside down and look into the vacuum tube. There should be three distinct, even jets of water. If there are not, contact Customer Service or a Polaris authorized Service Center for assistance.

Action: The cleaner is running in circles on its side.

- Solution:
1. Check filter bag, if full it can weigh the cleaner down on one side.
 2. Remove the head float and shake it. If there is water in the float, order a new one.
 3. The feed hose should float evenly on the surface of the pool.

Troubleshooting Worksheet

If these solutions do not result in improved performance, contact the Polaris dealer who sold you the cleaner or call Customer Service.

In order to provide faster and more convenient service, please have the following information available at the time of your call or when taking the Polaris in for service.

1. Serial #: _____
2. Wheel RPM: _____
3. Is the back-up valve cycling?
 Yes No
4. Is the feed hose the proper length?
 Yes No
5. Are the swivels rotating freely?
 Yes No
6. How often do you clean the filter screen inside the in-line filter?
 Never Once a Week
 Twice a Week Once a Month
7. Are the vacuum jets obstructed?
(While the cleaner is operating, hold it upside down and look into the vacuum tube. There should be four distinct, even jets of water.)
 Yes No
8. Is the drive train functioning?
(As you spin each wheel independently, all the wheels should spin.)
 Yes No



Rainbow Pool Products

PO Box 2388, Mansfield Qld 4122
Telephone STD 61-7-3849 5385
Facsimile STD 61-7-3849 5384
Email: info@rainbowpoolproducts.com.au
Web: www.rainbowpoolproducts.com.au