



# **TRI CHLORINE GENERATOR**

## **INSTRUCTION MANUAL AND WARRANTY CARD**



## THIS KIT CONTAINS:

**Part:**    **Qty:**    **Description:**

a.            1            TRi Power pack



b.            1            Chlorine generating cell



c.            1            Power pack bracket



d.            2            Reducing bushes



## WELCOME TO ZODIAC

Congratulations on your purchase of a product from the Zodiac range of pool care products. Zodiac products are designed to let you spend more time enjoying your pool and less on maintenance.

### **IMPORTANT INFORMATION**

YOU MUST READ THIS INFORMATION BEFORE INSTALLATION. ALWAYS READ THE LABEL AND OPERATION MANUAL BEFORE USING. PLEASE KEEP YOUR MANUAL AS IT CONTAINS YOUR WARRANTY.

## ZODIAC BELIEVES IN SAFETY FIRST

At Zodiac, we take safety seriously. Always exercise caution when using electrical appliances and follow the instructions. Failure to do so could result in permanent injury, electrocution or drowning.

### **GENERAL WARNINGS**

Zodiac saltwater chlorine generators are designed for domestic swimming pool use only. Contrary use could affect performance and void warranty.

Operating a chlorine generator without water flowing through the cell may cause a build up of flammable gases, resulting in fire or explosion.

Keep equipment out of reach of children.

A damaged supply cord should only be replaced by the manufacturer, authorized service agent or electrician.

When installing and using this electrical equipment, always follow basic safety precautions.

Before performing installation, disconnect all power.

For swimming pools, Australian standards recommend a minimum of 1 Part Per Million (ppm) of free available chlorine must be maintained at all times.

Service to Zodiac equipment should only be carried out by qualified and authorized pool professionals.

## **CHILD SAFETY**

Children should not be allowed to operate or perform maintenance on this product.

No one, particularly children, should sit, step, lean, or climb on any of your pool's operational system.

In the interests of child safety, all components of a pool's operational system should be located at least 3.5 metres away from the pool.

## **ELECTRICAL HAZARD**

To avoid accidental contact with lawn mowers and hedge trimmers, power cords should remain within sight and above ground at all times.

The Zodiac TRI Power pack must not come into contact with water and must be installed at least 3.5 metres from the inside wall of your swimming pool.

Should a lack of water be detected, the unit's electronic flow switch is designed to turn off the system. Interfering with the electronic flow switch could result in personal injury and/or damage to the cell.

One pump per electrical socket only (no ancillary equipment should be connected to the same outlet).

This appliance is not intended for use by persons (including children) with reduced physical, sensory or mental capabilities, or lack of experience and knowledge, unless they have been given supervision or instruction concerning use of the appliance by a person responsible for their safety.

Children should be supervised to ensure that they do not play with the appliance.

The installation of the chlorinator should be carried out by a qualified person in accordance with the Australian wiring rules AS/NZS 3000.

The chlorinator power pack should be located in the correct pool zone and connected to supply via a power outlet that is protected by a residual current device (RCD) having a rated residual operating current not exceeding 30mA. The power outlet should have a degree of protection suitable for the pool zone. Ensure that equipotential bonding of all parts of the pool installation is carried out.

# INSTALLATION GUIDE

The following steps will help you get up and running with your new Zodiac TRi Chlorine generator.



## POSITIONING THE POWER PACK

1. Locate a suitable space for the power pack bracket. It should be installed no further than 1.8 metres away from the cell - ideally in a filtration shed or close to the filtration equipment.

*PLEASE NOTE: if fixing to a post it must have a waterproof panel fitted (behind the unit), at least 450mm wide and 470 mm high.*

2. Using screws provided, fasten the bracket securely to the wall and position the power pack on the bracket. Plug into power point, but don't turn on the power.

## POSITIONING THE CHLORINE GENERATING CELL

*PLEASE NOTE: The cell should always be the last device placed on the water pipe (In the return line to the pool).*

3. Ensure the cell is placed horizontally, with the Inlet pipe connecting to the fitting closest to the cell lead.
4. Using screw barrel fittings (supplied), attach the cell to the pipe. If using 40mm pipe, you will need to fit the cell using the reducing bushes (also supplied).
5. When connecting the lead from the power pack to the cell match up the corresponding colours and pins, then fit the end cap.  
*(Note: Either RED wire can be connected to either RED pin on the electrode.)*
6. Plug your pool pump into the outlet socket in the bottom of the TRi (this will allow the TRi timer to control the filtration times)
7. Once all connections are together press the mains power switch to ON.

## NAVIGATION BUTTONS

Use the following UI buttons to access and select all menus and commands:



### **ON/OFF**

Turn UI power on/off.



### **UP/DOWN**

Scroll up/down within current menu to highlight a specific menu command.



### **MENU/BACK**

Enters into the main menu, and used to go back to previous menu.













### **SELECT/ENTER**

Select/enters current highlighted menu command. Display the next related command or activate the selected function

## USING INBUILT CLOCK AND TIMERS

When it comes to chlorination, every pool is different. To get what's right for you, you will need to set the unit's clock and timers.

### SETTING THE CLOCK

1. Switch  power on.
2. Wait for the start-up sequence to complete.
3. Press the  button to enter the MAIN MENU.
4. Use  /  buttons and scroll to SET CLOCK.
5. Press .
6. Use  /  buttons to set the hours.
7. Press  to save the hours.
8. Use the  /  buttons to set the minutes.
9. Press  to save the minutes.

TRi will then return to the MAIN MENU.

10. Press  to return to the operating screen.

*NOTE: The time is displayed in 24 Hour format*



## TURNING CHLORINE GENERATION ON

The chlorine generation of the TRi can be controlled in a number of ways:

1. Manually set to an output level, with the operating times determined by an external timer.
2. Using the in-built timers on the TRi unit (refer to 'The Timers')
3. Using a connection to an external controller (refer to 'Connecting to a controller').

To turn the chlorine generation on manually, press the ON/OFF button.

The output level can be set as described in 'Setting the Chlorine Output.'

*NOTE: For safety reasons, the TRi chlorine generator will continually dose chlorine for a maximum of 30 hours if left running with no 'OFF' time – unless connected to an external controller. After this time the TRi will switch to 'OFF'.*

## THE TIMERS

The Zodiac TRi chlorine generator comes with two inbuilt timers that switch the filtration and chlorination system on and off as required.

During swimming season, consider running the system for around 8 hours a day. This can be increased to 10 hours during periods of very hot weather.

In winter, it may only be necessary to run your pool's filtration system for 4 hours a day. These shorter periods of activity will lengthen the life of the unit's electrode.

For best year round results, set the unit to operate during the cooler hours of the early morning, evening or when swimmers are using the pool.



















## PROGRAMMING THE TIMERS

To activate the timer, you will need to enter both an ON and OFF time. If no OFF time is entered, the chlorine generator will switch off at the default time of 12:00am (0:00).

You will know that a valid time has been entered when a "T" Symbol is displayed in the top right hand corner of the LCD display when the unit is displaying the 'operating screen'.

## USING INBUILT CLOCK AND TIMERS







To program the timer:

1. Press the  button.
2. Press  button to move arrow to 'SET TIMERS'.
3. Press  to enter the 'SET TIMERS' menu.
4. Press  /  to select the timer you wish to set. (Timer 1 or Timer 2)
5. Press .
6. Press  /  to set the hours (on time).
7. Press  to save the hours.
8. Press  /  to set the minutes (on time).
9. Press  to save the minutes.
10. Press  /  to set the hours (off time).
11. Press  to save the hours.
12. Press  /  to set the minutes (off time).
13. Press  to save the minutes.

TRi will return to the 'SET TIMERS' menu.

### CLEARING THE TIMERS

To clear the timer:

1. Press the  button.
2. Press  /  button to scroll to 'SET TIMERS'.
3. Press  to enter the 'SET TIMERS' menu.
4. Press  /  to scroll to 'CLEAR TIMERS'.
5. Press .

A confirmation message will appear on the screen.

### EXTERNAL TIME CLOCK

At times, it may be desirable to control chlorine generation using an external time switch. If the chlorine generator is turned ON, and the external timer fails to switch the mains power off within 30 hours, the Zodiac TRi will automatically stop chlorinating in order to prevent over chlorination.

To set the chlorine generator to run from an external clock:

1. Clear the Timer by following the procedure outlined in '*Clearing the Timers*'.
2. Press the  button to turn the chlorine generator on.

# CHLORINE OUTPUT LEVELS

## SETTING THE CHLORINE OUTPUT



The amount of chlorine required by your pool is dependent on a number of factors including the size of the pool, the number of users and the climate.

Output will appear as a percentage on the screen readout, monitor the level according to the reading over time will help ensure optimum output.

*For users who upgrade to the TRi-PRO model, chlorine output will be controlled automatically.*



To set Chlorine Output levels:

1. Press the  button to turn the chlorine generator on.
2. Press the  /  buttons to set the desired output level.

*PLEASE NOTE: if using a pool cover you will need to reduce the chlorine production substantially, please use LOW mode if you use a cover. Simply press LOW button.*

# CORRECT SETTINGS FOR YOUR TRI CONTROLLED POOL

## CORRECT SETTINGS FOR YOUR TRI CONTROLLED POOL

	Free Chlorine (ppm)	pH	Total Alkalinity (ppm)	Calcium Hardness (ppm)	Cyanuric Acid (ppm)	Salt Level (ppm)	Sensors
<b>Australian Standard</b>	1 – 3	7.2 – 7.8	80 – 300	90 – 300	30 – 50	4000 - 7000	
<b>Ideal reading/range</b>	1 – 3	7.5	80 – 140	90 – 300	50	4000 ppm at 27°C*	
<b>To increase*</b>	Add chlorine or increase output of equipment	Add buffer or soda ash (sodium carbonate)	Add sodium bicarbonate	Add calcium chloride	Add Cyanuric acid	Add Salt	
<b>To decrease*</b>		Add muriatic acid	Add muriatic acid or dry acid	Partially drain & refill pool	Partially drain & refill pool	Partially drain & refill pool	
<b>Frequency of testing (in peak season)</b>	Weekly	Weekly	Weekly	Weekly	Weekly	Monthly	Quarterly







## CONNECTING TO A CONTROLLER

If you use an automation or controller system to control your pool you will need to configure your TRi Chlorine generator to allow “communication” between the two.



**You must set the controller type on the TRi before making the wiring connection.**

### SETTING THE CONTROLLER (To be done before making a wiring connection)

1. Switch power to the TRi unit on.
2. Wait for the start-up sequence to complete.
3. Press the  button.
4. Press the  button to scroll down to ‘CONTROLLER’.
5. Press  to enter the controller menu.
6. Press  /  to highlight the controller being used.
7. Press  to save the controller setting.
8. TRi will return to the main menu.
9. Press  to return to the operating screen.

### ATTENTION JANDY 'REV L' OR LATER USERS

It is critical that the controller setting be set to the correct Zodiac, Jandy or Pentair controller designation. There are a number of different revisions locked into the TRi software. Please see the user manual to determine the model and/or revision you are using. If the incorrect setting is selected, damage can be caused to the Jandy Aqualink Control Unit.

### CAUTION WHEN WIRING TO A CONTROLLER

#### IMPORTANT

Wiring of the controller should be completed by an authorised pool equipment installer.

Before any wiring connections/disconnections ensure mains power is removed from both the controller and the Zodiac TRi unit.

When connected to a controller, the TRi Chlorine generator acts as the 'slave' - responding to requests. This means timer settings are ignored and the output settings cannot be changed, although all other 'menu' functions are still accessible, except for LOW and BOOST modes.

### WIRING TO A CONTROLLER

The following instructions should be read in conjunction with the installation guide provided with the Controller.

1. Remove silver 'dress' cover by pressing in at the sides where indicated below and lift.



2. Remove the two screws which attach the lower cover to the main unit:



## CONNECTING TO A CONTROLLER

3. Remove the lower cover from the TRi unit.

*NOTE: If using either pH upgrade or PRO unit – carefully disconnect the ribbon cable from the TRi unit.*

4. Remove the small white bung closest to the centre of the lower panel of the TRi unit.
5. Thread the controller cable through the hole (a grommet may be necessary depending on the size of the cable being used).



6. Attach a cable tie to the controller cable as shown in the diagram. The wiring colour codes are outlined below:



Depending on the make of the Controller, make the following wiring connections:

### **Polaris EOS / Jandy / Zodiac Aqualink / Aqualink TRi**

Green wire (0V) to '0V' terminal on the TRi

Red wire to the (+V) 'POS' terminal on the TRi

Yellow/White (B) wire to 'B' terminal on TRi

Black wire (A) to 'A' terminal on TRi

### **Pentair Intellitouch**

GREEN wire to 'B' terminal on TRi

Red wire to 'POS' terminal on TRi

Yellow wire to 'A' terminal on TRi

Black wire to '0V' terminal on TRi



### TESTING THE WIRING CONNECTION

Once a connection has been made between the Controller and the Chlorine generator, it will need to be tested.

1. Turn on the power to the Controller and the Zodiac TRi.
2. If successful, a 'F' symbol will appear in the top right hand corner of the screen after about 20 seconds.
3. If the controller does not connect, turn power off to both the devices and try again.

### VERIFY THE WIRING CONNECTIONS

To verify the connection:

1. Switch the TRi unit on and check the controller setting (follow instructions under 'SETTING CONTROLLER').
2. Re-test the connection.

*Note: For safety reasons, the Zodiac TRi reverts to the OFF setting if the communication connection is lost.*

### CONNECTION TO CONTROLLER FOR POOL/SPA COMBINATIONS

To connect a Zodiac TRi unit to Pool or Spa Valves, you will need to make a "splice" into the control lines from the Controller, located inside the controller itself.

For further information, consult the installation manual of the Controller being used.

## SETTING THE MODE TO LOW: IMPORTANT IF USING A POOL COVER

If your pool has a cover, you should set the output level to “low”. This is also known as “winter” mode. Reducing your chlorine output will help prevent damage to your pool’s cover and other equipment.

### MANUAL SETTING

1. To select Low mode press .

This will drop the chlorine output to around 10%.

2. ‘Low’ will appear on the screen.

*Note: Low or Winter mode cannot be selected when TRi is being controlled by an external controller.*

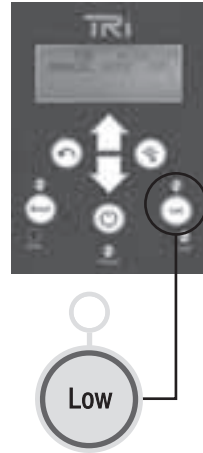

### AUTOMATIC SETTING

The Zodiac TRi can be connected to the valves of an automatic pool/spa system.

When the input from the valves is set to ‘Low’ the TRi will automatically revert to ‘Low’ mode and the output will be locked at 10%

Details of the wiring connection are outlined in the “*Connection to Automatic Pool/Spa Valve*” section of this manual.

**For users who have upgraded to the TRi-pH or TRi-PRO, the automatic pH/ACL control function is disabled when in LOW mode.**

## THE BOOST SETTING

At times your pool may require a larger than normal application of chlorine. The Boost function is used to rapidly add chlorine.

In BOOST or “Superchlorinate” mode, output settings are temporarily overridden and the chlorine generator runs for 24 hours at 100% Chlorine Production.

In ‘TIMER’ mode, the circulation pump will run for 24 hours, before automatically reverting to previous output / timer settings.

In ‘MANUAL’ mode, the chlorine generator will run at 100% for a cumulative total of 24 hours before reverting to the previous output setting.

### NOTE:

The ‘BOOST’ mode cannot be engaged under the following circumstances:

- 1) If the TRi is in the ‘OFF’ operating mode. The chlorinator must be ‘ON’ for BOOST to be engaged.
- 2) If you have upgraded to the TRi-PRO
- 3) Or from the front panel when the TRi is being controlled by an external controller.

In most cases a BOOST function can be set from the controller menu.

Consult your third party controller manual for more information.

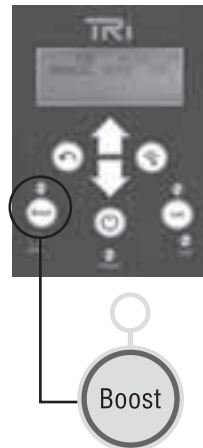

## SETTING THE BOOST MODE

To activate the BOOST setting:







Press the  button.

‘BOOST’ will be displayed on the screen and chlorine generation will commence.

## HELP AND TROUBLESHOOTING

The Zodiac TRi chlorine generator automatically provides a number of inbuilt warnings that can help identify problems and offer solutions.

To access the HELP menu:

1. Press the  button.
2. Using the  /  buttons, scroll to the 'HELP/DIAG' menu.
3. Press  to enter the 'HELP/DIAG' menu.
4. Once in the 'HELP/DIAG' menu, use the  /  buttons to scroll to the error/warning that has been displayed.
5. Press .

A number of suggested solutions are momentarily displayed, in order of priority.

After displaying, the TRi automatically reverts back to the 'HELP/DIAG' menu.

6. To exit to the default operating screen wait ~5 seconds  
OR press the  button.

To keep your TRi Unit in the best possible condition it is recommended regular maintenance should be performed.

## INSPECTING AND CLEANING THE ELECTRODE

In areas that experience calcium hardness the TRi electrode will benefit from cleaning.

To clean your electrode:

1. Switch off the filter pump and chlorine generator; close necessary valves and unplug the cell terminal cap.
2. Unscrew the retaining ring and remove the electrode. If calcium buildup is present, immerse the electrode in cell cleaning solution without immersing the terminals.
3. We recommend using Zodiac Salt Chlorinator Cell Cleaner to clean the electrode. However you can mix your own by carefully adding one (1) part of Hydrochloric (Muriatic) acid to ten (10) parts water. Stronger solutions will shorten terminal life.
4. Allow the cleaning solution to dissolve the calcium deposits for about 10 minutes. Dispose of the cleaning solution at an approved Council Depot and never into storm water or sewage drains.
6. Rinse the electrode in clean water and re-fit the electrode in the cell housing.
7. Replace the cell head and plug assembly and reset valves and switches. Turn pump and TRi on.
8. Confirm chlorine output and settings on the power pack. Timer settings will be automatically retained.



### **NO FLOW**

Diagnosis: Insufficient water flow in the cell.  
This could mean the circulation pump has ceased to function, or the filter needs cleaning. The chlorine output will be turned off at this time.

### **CHECK SALT**

Diagnosis: Salt level is between 3000 and 4000 ppm, depending on the water temperature.

Always maintain a salt level above 4000ppm. if you don't know what your salt level is or how to test it, consult your local pool care professional.

### **CHECK POWER SUPPLY**

Diagnosis: There could be a problem with the power supply. Turn power off at the power point and consult your local pool care professional.

### **CLEANING**

Diagnosis: The cell is in the process of reversing polarity.  
Wait approximately 5 minutes and chlorine production should resume as normal.

**Additional information about this product can be found at [zodiac.com.au](http://zodiac.com.au)**

For further information and assistance please consult your local pool professional.

**Your Local Dealer:**

## Express Warranty\*

Zodiac Group Australia Pty Ltd (**Zodiac Australia**) warrants that the Zodiac TRi Saltwater Chlorine Generator will be free from defects in materials and workmanship for the period of 3 years from the date of purchase.

**\* The warranty applicable to commercial application is limited to 12 months from the date of installation.**

### Conditions

- 1 This express warranty only applies if the Product has been purchased from a dealer authorised by Zodiac Australia to supply it (**Authorised Dealer**).

Purchase from an Authorised Dealer ensures that the product is a genuine Zodiac product, that it is the version designed for Asia Pacific conditions, and that the Purchaser has access to appropriate technical knowledge and advice.

- 2 Zodiac Australia's liability under this express warranty is limited, at its option, to the repair or replacement of the Product or the payment of the cost of having the Product repaired or replaced.
- 3 This express warranty does not apply in the following circumstances:
  - (a) if the Product has not been installed in accordance with Zodiac's installation instructions;
  - (b) if the Product has been modified other than as authorised by Zodiac Australia or if a component part has been replaced by a part that is not a genuine Zodiac product;
  - (c) if a defect results from use of the Product outside recommended operating conditions; or
  - (d) if a defect results from damage (including damage to any internal electronics) caused by a power surge or lightning strike.

Zodiac chlorinators are designed and tested in accordance with International Standard EN 61000-6-1 immunity measurements. They are designed to tolerate minor fluctuations (2000 volts) in power supply that can be reasonably expected to occur in the energy grid. They will not tolerate power surges outside these limits nor will they withstand lightning strikes.



- 4 Without limiting 3 above, products sold by Zodiac Australia are designed for use with swimming pool water balanced in accordance with Australian Standard AS3633-1989 with a pH range of 7.0 - 7.8. Maximum chlorine readings should not exceed 4ppm. Where pool water is not maintained within these parameters, Zodiac Australia will not be responsible under this express warranty for any resulting damage, including damage caused by corrosion, scaling or stress loading.
- 5 Replacement parts supplied under this express warranty are warranted to be free from defects in materials and workmanship for the remainder of the warranty period or for 12 months from the supply of the replacement, whichever is longer.
- 6 Warranty claims relating to replacement of the electrodes for LM series, C series, Duo Clear and D series chlorinators are subject to the following pro-rata pricing procedure. The Purchaser must pay for the replacement electrode a proportion of the cost equal to that proportion of the warranty period during which the original electrode functioned effectively. The warranty period for the replacement electrode is the remainder of the warranty period for the original electrode or 12 months from the supply of the replacement, whichever is longer. The Purchaser must pay full cost for any replacement electrodes after the first replacement.

### **Product warranty registration**

- 7 Purchasers should register their Products as soon as conveniently possible after purchase by completing a Product Warranty Registration Form and posting it to Zodiac Australia at the address shown on the Form or by registering online at [www.zodiac.com.au](http://www.zodiac.com.au).
- 8 Product registration must occur, and proof of purchase must be received by Zodiac Australia, prior to any warranty work being approved. Where applicable, a serial number, installation date and name of installer is required as part of the registration process.

## **How to make a warranty claim**

- 9 The Purchaser must telephone or email Zodiac Australia Customer Service and obtain a warranty ID number for the warranty claim.

Contact details are:

### **Zodiac Group Australia Pty Ltd**

219 Woodpark Road  
Smithfield NSW 2164

### **Customer Service**

Telephone: 1800 688 552

Email address: [aftersales@zodiac.com](mailto:aftersales@zodiac.com)

- 10 Zodiac Australia reserves the right to determine, in relation to each warranty claim, whether the Product should be returned to the Authorised Dealer at the address where the Purchaser purchased the Product or whether warranty service will be provided in the field, repaired at a Zodiac workshop or at the premises of an authorized Zodiac warranty agent.
- 11 If it is necessary for the Purchaser to incur freight charges in making a valid claim under this warranty, Zodiac Australia will reimburse the Purchaser for charges reasonably incurred upon proof of the charges.

## **Additional guarantees, rights and remedies**

### **Australian Purchasers - Guarantees under the Australian Consumer Law**

- 12 The benefits of this express warranty are in addition to other guarantees, rights and remedies Australian consumers have under the Australian Consumer Law.
- 13 Zodiac Australia products come with guarantees that cannot be excluded under the Australian Consumer Law. You are entitled to a replacement or refund for a major failure and for compensation for any other reasonably foreseeable loss or damage. You are also entitled to have the goods repaired or replaced if the goods fail to be of acceptable quality and the failure does not amount to a major failure.

### **Purchasers in other Countries**

- 14 The laws and regulations of other countries may confer on Purchasers in those countries additional rights and remedies. To the extent that they cannot be excluded or modified, Purchasers have the benefits of those rights and remedies in addition to the benefits of this express warranty. To the full extent that it is permissible to do so, those additional rights and remedies are excluded or modified so as to be consistent with Zodiac Australia's express warranty.

### **INCONSISTENCY WITH WARRANTY STATEMENTS IN PRODUCT MANUALS OR OTHER DOCUMENTS ACCOMPANYING PRODUCTS**

If any warranty statements in a Zodiac Australia product manual or other document are inconsistent with the above Express Warranty and Guarantees, the above overrides and replaces the inconsistent statements.



# ZODIAC



Zodiac is a registered trademark of Zodiac Group Australia Pty Ltd  
ABN 87 002 641 965

## **ZODIAC CUSTOMER SERVICE CENTRE**

Zodiac Group Australia:

219 Woodpark Rd, Smithfield,  
NSW 2164 Australia

Tel: 1800 688 552

Fax: 1300 781 688

Email: [aftersales@zodiac.com.au](mailto:aftersales@zodiac.com.au)

[www.zodiac.com.au](http://www.zodiac.com.au)

Due to constant developments and improvements,  
specifications may change without notice.  
Improper use could affect performance and void warranty.

© Copyright Zodiac Australia Ltd 2013

W176781 REVA



# **PH UPGRADE**

# **INSTRUCTION**

# **MANUAL AND**

# **WARRANTY CARD**



# THIS KIT CONTAINS:

Part:	Qty:	Description:
1.		TRi-pH Module (if purchased separately)
2.		Hole saw
3.		Tubing
4.		POD assembly
5.		pH sensor
6.		pH sensor cable
7.		Sensor calibration fluid
8.		Anti Fume Cap 5lt and 15/20lt
9.		Ceramic Weight
10.		Weight barb fitting (for end of tube)



# WELCOME TO ZODIAC

Congratulations on your purchase of a product from the Zodiac range of pool care products. Zodiac products are designed to let you spend more time enjoying your pool and less on maintenance.

## **IMPORTANT INFORMATION**

**YOU MUST READ THIS INFORMATION BEFORE INSTALLATION.  
ALWAYS READ THE LABEL AND OPERATION MANUAL BEFORE USING.  
PLEASE KEEP YOUR MANUAL AS IT CONTAINS YOUR WARRANTY**

At Zodiac, we take safety seriously. Always exercise caution when using electrical appliances and follow the instructions. Failure to do so could result in permanent injury, electrocution or drowning.

## **GENERAL WARNINGS**

Zodiac saltwater chlorine generators are designed for domestic swimming pool use only. Contrary use could affect performance and void warranty.

Operating a chlorine generator without water flowing through the cell may cause a build up of flammable gases, resulting in fire or explosion.

Keep equipment out of reach of children.

A damaged supply cord should only be replaced by the manufacturer, authorized service agent or electrician.

When installing and using this electrical equipment, always follow basic safety precautions.

Before performing installation, disconnect all power.

For swimming pools, Australian standards recommend a minimum of 1 Part Per Million (ppm) of free available chlorine must be maintained at all times.

Service to Zodiac equipment should only be carried out by qualified and authorized pool professionals.

## **CHILD SAFETY**

Children should not be allowed to operate or perform maintenance on this product.

No one, particularly children, should sit, step, lean, or climb on any of your pool's operational system.

In the interests of child safety, all components of a pool's operational system should be located at least 3.5 metres away from the pool.

## **ELECTRICAL HAZARD**

To avoid accidental contact with lawn mowers and hedge trimmers, power cords should remain within sight and above ground at all times.

The Zodiac TRi Power pack must not come into contact with water and must be installed at least 3.5 metres from the inside wall of your swimming pool.

Should a lack of water be detected, the unit's electronic flow switch is designed to turn off the system. Interfering with the electronic flow switch could result in personal injury and/or damage to the cell.

One pump per electrical socket only (no ancillary equipment should be connected to the same outlet).

This appliance is not intended for use by persons (including children) with reduced physical, sensory or mental capabilities, or lack of experience and knowledge, unless they have been given supervision or instruction concerning use of the appliance by a person responsible for their safety.

Children should be supervised to ensure that they do not play with the appliance.

The installation of the chlorinator should be carried out by a qualified person in accordance with the Australian wiring rules AS/NZS 3000.

The chlorinator power pack should be located in the correct pool zone and connected to supply via a power outlet that is protected by a residual current device (RCD) having a rated residual operating current not exceeding 30mA. The power outlet should have a degree of protection suitable for the pool zone. Ensure that equipotential bonding of all parts of the pool installation is carried out.



## IMPORTANT THINGS TO REMEMBER

There are a number of very important things to remember when setting up and maintain your TRi-pH.

1. It is absolutely essential to have the pool water in good balance before turning the TRi-pH on so ensure that the pool water is correctly balanced (see page 10 of the TRi owners manual for complete list).
2. Do NOT under any circumstances store the acid container underneath the power pack unit. Rising acid fumes will cause considerable damage to the unit and this will NOT be covered under warranty
3. Store your acid container safely and out of reach of children. If the acid container is stored in a shed always ensure there is adequate ventilation for fumes to escape
4. Do NOT dilute the pool acid. TRi is a high performance, high durability product and is designed to use straight acid from the container, so you do not have to dilute it.
5. Always handle the sensors with care and never touch the sensor tip with your fingers. If the sensor needs cleaning use soap and water and clean thoroughly
6. If installing TRi-pH on a new pool you may find that a higher than usual acid demand is expected. This will settle after a few weeks so please monitor its needs during this 'settling' phase

# QUICK START INSTALLATION GUIDE

The following steps will help you get up and running with your new Zodiac TRi pH Upgrade Module. If you purchase your Zodiac TRi pH as a complete unit go straight to section - Installing Sensors.

## IF YOU HAVE PURCHASED THE TRi PH UPGRADE:

How to install the TRi pH upgrade unit:

1. Turn mains power off and remove the existing top cover.



2. Unscrew the bottom 2 screws on the main body panel and remove the bottom cover.

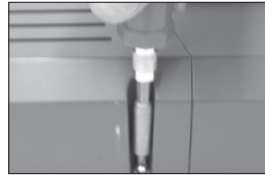

3. Plug the ribbon cable from the pH unit into the pH connector on the TRi unit.

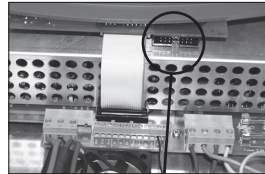

4. Refit the 2 removed screws as well as the top cover with the new pH unit installed.

## INSTALLING THE PH SENSOR POD

### Installing the POD and sensor

TRi sensor POD integrates into a simple unit, a pH sensor and a pH corrective solution one way valve.

The sensor POD must be positioned after filtration system and before TRi cell (and after any heating system).

Sensor POD must always be positioned onto a horizontal pipe so that the pH sensor is vertical (45° maximum tolerance).

**Warning: Never store the acid container underneath or near the TRi-pH power pack**

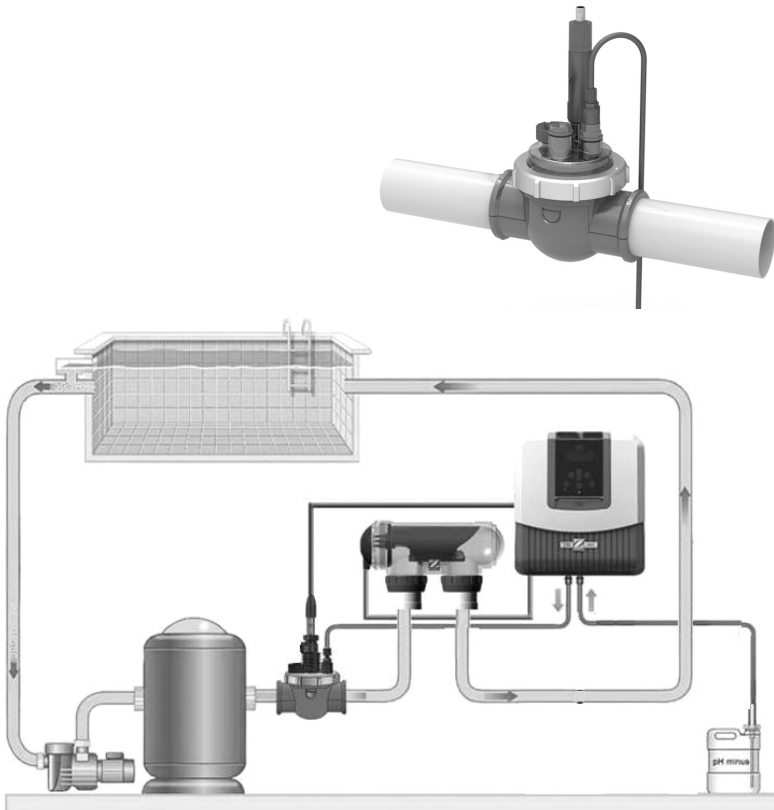

## PREPARING PH SENSOR

1. Identify a straight section of horizontal pipe of appropriate length after the filter but before the salt cell (30cm is recommended).
2. Disassemble sensor POD to get lower part of POD clamp with 2 holes (picture 1).
3. Place the lower part of POD clamp upside down into position on the selected length of piping
4. Now mark the location of the 2 holes to be made into piping using a pencil or marker (picture 2).

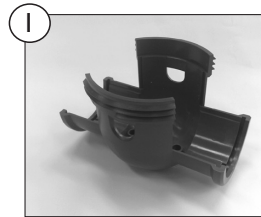

5. Drill the 2 holes using the provided hole saw. Ensure that holes are perfectly smooth around the edges (picture 3).
6. Position the upper part of POD clamp by sliding it into the 2 previously drilled holes (picture 4).

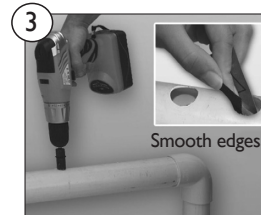
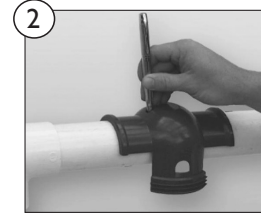

**Warning: Arrows on upper part of POD clamp indicate direction of water flow**

7. Interlock the lower part of POD clamp onto the upper part already in place on piping. (if using 40mm pipe use the spacer provided)
8. Fit the POD cap on top of upper POD clamp, re-fit locking ring and tighten firmly using provided tool.
9. Install the pH sensor by firmly screwing into the POD cap.
10. Connect the sensors with the provided cable to the appropriate sockets on the TRI power pack.

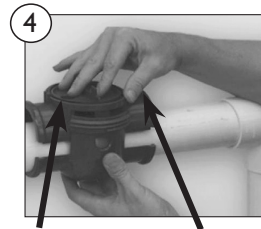

Ensure flow arrows are in the correct

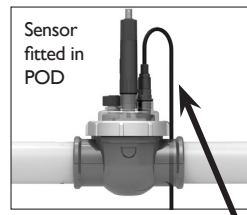

Injection tube fitted to one way valve

## FITTING THE ACID DELIVERY SYSTEM

**Now the POD is in place and the sensor is connected it is time to connect the suction and injection tubes**

1. To connect the suction and injection tubes please 'soften' the ends of the tubing by immersing in warm water for a few minutes.
2. Remove the small face panel that covers the peristaltic pump
3. The suction tube is connected to the left hand side of the peristaltic pump.
4. Use a length of tube long enough to reach from the liquid container to the control box and feed the tube through the black rubber grommet in the 'anti-fume' cap (2 sizes are included 5lt and 15/20lt).
5. Once the cap is on the tube, now fit the small ceramic weight on the suction tube and then fit the small blue barb fitting to the end of the tube to prevent the weight from falling off. (see picture A)
6. Now connect the injection tubing to the injection side (right hand) of the peristaltic pump
7. Firstly remove the small screw fitting and slide it onto the tubing then fit the end of the tube onto the one way valve located in the sensor POD and screw down the fitting locking it into position (this is the injection point for the solution being delivered) (see picture B)



## FITTING THE ACID DELIVERY SYSTEM

8. Once all connections are made place the suction line into the container and screw the anti fume cap down into position. (see picture C)

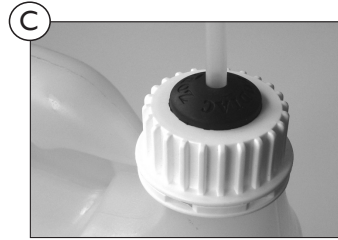

### **PLEASE TAKE NOTE OF THESE IMPORTANT POINTS WHEN CONNECTING PH CONTROL**

- **ONLY** use straight hydrochloric (muriatic) acid, do not dilute or use any other type of acid.
- **DO NOT** store the acid container in the filtration shed unless there is adequate ventilation as the fumes will corrode any items in the shed - including your pool care equipment. Store your acid in a secure location away from any hazards
- **DO NOT** store the acid container directly under or near the TRi power pack.









**Failing to comply with this could void your warranty.**

## TESTING / PRIMING THE ACID PUMP

After installation it's recommended the acid pump be tested and the acid pump 'primed'.

**WARNING!** Before testing the pump, ensure all acid supply and delivery connections are secure. Always use appropriate safety equipment when handling acid.

To test the Acid Pump:

1. Press the  button.
2. Press  /  buttons to move arrow to 'pH SETUP'.
3. Press  to enter the 'pH SETUP' menu.
4. Use the  /  buttons to highlight 'TEST ACID' and press  to enter test acid menu.
5. A warning will momentarily be displayed, then press  again to start the pump.

The acid pump will run for approximately 10 minutes and automatically switch off. (If the pump needs to be turned off immediately, press the

 button)

*NOTE: Steps 1 to 5 may require repeating several times depending on the length of the acid supply tube.*

# PH CONTROL

The following information about pH is critical to the successful operation of your swimming pool.

For advice and supply of the correct products, consult your local pool care professional.

## PREPARING THE POOL

The TRi-pH unit is designed to maintain the pH of the pool.

By ensuring that the pool is correctly balanced at the outset will decrease the chance of problems, during the first days of operation.

## PH LEVELS

Ideal pH range for most pools is 7.2 – 7.6

All chemical balances in the pool are affected by pH, making it the single most important element of swimming pool chemistry.

1. To lower pH level use diluted hydrochloric acid or phosphoric acid (*this will be done automatically by the TRi-pH once connected*).
2. To raise pH. Use soda ash.

## TOTAL ALKALINITY (TA) LEVELS

Ideal TA level range: 80-140 parts per million (PPM)

Total Alkalinity is a measure of alkaline chemicals in your pool and can be used as a “buffer” to control pH levels.

If TA levels are too low, it may stain pool surfaces and make controlling pH levels difficult.

If TA levels are too high, scaling may be evident on pool walls and in the chlorinator cells.

1. To raise total alkalinity. Add pH buffer or stabilizer, according to manufacturer’s instructions.
2. To lower total alkalinity. Add approximately 400ml of hydrochloric acid daily.
3. When total alkalinity has stabilized within the prescribed ideal range, you may need to adjust the pool’s pH.



## CHLORINE LEVELS

Ideal chlorine level range: 1-3 parts per million (PPM).

Prior to starting the TRi-pH the chlorine level can be raised using either liquid or granulated chlorine.

## SALT LEVELS

Ideal Salt level range: 3000 – 5000 parts per million (PPM).

Efficient and correct operation of the electrolytic cell requires a sufficient amount of salt in the water.

Not enough salt may cause a reduced chlorine output level and a reduced life of the cell.

Too much salt will cause eye irritation and a salty taste in the pool water.

### **Filter / Skimmer**

In addition to the pool chemistry being important, the condition of the filtration system and skimmer baskets must be assessed. If required, backwash the filter and remove debris from the pool skimmer basket(s).

## AUTOMATIC DETECTION









When the Zodiac TRi Unit automatically detects the presence of a TRi pH module it displays the pool's pH set point.

1. The message 'pH CONTROL' appears on the third line of the screen.
2. The pool's pH "set point" is displayed at the bottom of the screen.

*NOTE: From factory, the acid delivery is disabled and the pH set point will be displayed as "—". Refer to 'Enabling and disabling the Acid Pump' for more information. When the acid delivery is enabled, the pH set point is displayed at the bottom of the screen.*

With pH sensor and acid delivery components successfully set up, the TRi unit needs to be calibrated and set up for pH control.











Ensure that mains power is supplied to the TRi, turn the pool pump off and isolate the pool water so the pH sensor can be safely removed.

1. Remove the pH sensor and clean if necessary using soapy water. (Avoid touching the glass tip of the sensor). Rinse off with fresh water.
2. Place the pH sensor in a sample of pH calibration solution with a pH level of 7.5.
3. Leave the sensor immersed in the solution for a minimum of 30 seconds to settle.
4. From the default operating screen, press .
5. Use the  /  buttons to highlight 'pH SETUP', then press .
6. Use the  /  buttons to highlight 'CALIBRATE pH', then press .
7. Observe the 'CURRENT' pH reading. If the reading is above 8.2 or below 6.4, there may be a problem with the sensor or pH unit. **DO NOT CONTINUE** and refer to your local pool professional for assistance.
8. If the CURRENT reading is within the above limits, press the  button to begin calibration.
9. When calibration is complete, note the new pH reading. If the reading is not 7.5, repeat the previous 5 steps. (If the current pH still doesn't read 7.5 refer to your local pool professional for assistance.)
10. Press the  button twice or wait 30 seconds and the TRi unit will return to the default operating screen.

## PH SET POINT

The default pH setting of your Zodiac TRi is 7.2. This can be changed according to your pool's requirements.

To change the pH set point:

1. Calibrate the pH sensor.
2. From the default operating screen, press .
3. Use the  /  buttons to highlight 'pH SETUP', then press .
4. Use the  /  buttons to highlight 'pH SETPOINT', then press .
5. Use the  /  buttons until the desired "set point" is achieved  
Then press the  to save the desired set point then press  twice to go back to operating screen or wait for one minute.

## SETTING THE POOL SIZE











**This setting controls the maximum amount of acid which is delivered to the pool daily. Your unit comes factory set on pool size 2.**

**The recommended settings for various size pools are as follows:**

- 1: For small pools up to 40 000 litres
- 2: For medium pools 40 000 to 60 000 litres
- 3: For large pools 60 000 to 100 000 litres
- 4: For over size pools above 100 000 litres

The above settings are a guideline only. It is recommended that a lower setting be selected initially – this setting can be increased at a later time if insufficient acid is being dosed to maintain the correct pH level.

To set the pool size, follow the procedure below:

1. From the default operating screen, press .
2. Use the  /  buttons to highlight 'pH SETUP', then press .
3. Use the  /  buttons to highlight 'POOL SIZE, then press .
4. Use the  /  buttons to select the pool size to the desired value.  
Then press  to save.
5. Now press  twice to return to the main operating screen.  
(Or this will automatically happen after one minute)

**NOTE: Acid is dosed into the pool while the chlorinator and filtration system are running.**

**WARNING! It is advised that the pool size be set as low as possible to avoid overdosing acid into the pool.**

### **USING PH CONTROL**

The TRi-pH is now ready for use with automatic pH control.

1. Set 'ON' and 'OFF' times.
2. Select desired chlorine output level.
3. Enable the Acid Pump (Refer to Enabling and disabling the Acid Pump.)

The TRi unit will now automatically maintain the pH level of the pool.

## REGULAR CHECK UPS

Although automatic pH control reduces the need for regular testing, there are still a number of checks to ensure the safe operation of the system and a pleasant swimming experience.

### **Always check:**

Acid supply levels.

Total Alkalinity.

The accuracy of the pH sensor by manually checking the pH level.

That the pH sensor is cleaned and re-calibrated.

### **Acid Pump and Feed Line Maintenance**

1. Lubricate the pump squeeze tube every 6 months. Use lubricant recommended by your local pool care professional
2. The pump squeeze tube is a wearing item and may need to be replaced during the life of the product, regular checking will let you know when this is needed.

### **Please Note: Peristaltic pump and associated fittings, tubing etc are covered by a 1 year limited\* warranty only**

3. The acid injection point and feed lines should be checked for blockages and be cleaned as required. Always ensure you wear appropriate safety equipment when handling acid

\*see warranty terms and conditions at the end of this manual

## ADJUSTING TOTAL ALKALINITY (TA)

As acid is added automatically over time, total alkalinity levels will decrease and may result in inconsistent pH levels.

It may be necessary to add a “buffer” element to the water in your pool.

As it is not recommended to add acid after adding a “buffer”, temporarily disable the acid pump (refer to Enabling and disabling the acid pump).

### ENABLING AND DISABLING THE ACID PUMP.









In the interests of safety, the Zodiac TRi-pH is shipped with the acid pump disabled.

When a TRi-pH is connected, the acid pump is programmed to begin operation after approximately 8 hours of being activated. This can be overridden by disabling the acid pump.

When the acid pump is disabled, the set point reading will be replaced with “---” until the acid pump is re-enabled.

After 8 hours, the deactivated pump will automatically re-enable itself.

#### To enable the acid pump manually:

1. From the default operating screen.
2. Press the  button.
3. Press  /  buttons to move arrow to ‘pH SETUP’.
4. Press  to enter the pH menu.
5. Use the  /  buttons to highlight ‘ACID PAUSED’ (OR ‘ACID ENABLED’).
6. Press  to toggle between ‘ACID ENABLED’ and ‘ACID PAUSED’.
7. Once the appropriate selection has been made, press  twice or wait ~60 seconds for the TRi to revert back to the default operating screen.

When using automatic pH control, the requirement for regular pool chemistry checks is lowered. It is however, necessary to regularly check a number of critical things to ensure safe and correct operation of the system:

## **CLEANING THE PH SENSOR**

When cleaning the sensor avoid using solvents such as acetone. Always calibrate after cleaning.

To clean the sensor:

If the electrode has become coated with oil or grease, carefully wash the electrode under warm tap water using dish-washing detergent. Rinse the sensor thoroughly with clean tap water.

If the above procedure does not work, soak the sensor in a diluted hydrochloric acid (HCL) solution for 10 seconds.

This can be purchased from your local pool professional or made by carefully adding one (1) part of Hydrochloric (Muriatic) acid to ten (10) parts water in a suitable container. **ALWAYS ADD ACID TO THE WATER.** After soaking, rinse the sensor thoroughly in clean tap water and re calibrate before use.

If the above two procedures fail to restore the sensor, the sensor should be replaced.



## **ERRORS AND WARNINGS. WHAT THEY MEAN.**

### **PH LOW**

Diagnosis: the pH Level in the pool has dropped too far below the set point. This could indicate the POOL SIZE setting is too high, causing acid to overdose or the pH sensor is faulty or needs calibration and/or cleaning. Manually test the pool's pH before further investigation, if all equipment is operating fine then adjust your pool setting to a lower value.

### **PH ERROR**

Diagnosis: the acid pump has completed its dosing cycles without reaching the set point. This could indicate the acid supply is empty, the pH sensor is faulty or needing calibration/cleaning, the Pool size is set too low or the acid pump is faulty. To clear this error please hold down the select button for 5 seconds (the TRi must be on).

**Additional information about this product can be found at [zodiac.com.au](http://zodiac.com.au)**

For further information and assistance please consult your local pool professional.

**Your Local Dealer:**

# EXPRESS WARRANTY AND GUARANTEES

## Express Warranty

Zodiac Group Australia Pty Ltd (**Zodiac Australia**) warrants that the TRI-pH Chlorinator will be free from defects in materials and workmanship. The Cell and Power Pack is warranted for the period of three (3) years, if used in a domestic/residential pool. The Peristaltic pump, sensors and other extraneous equipment are conditionally warranted for the period of twelve (12) months, if used in a domestic/residential pool.

### Conditions

- 1 This express warranty only applies if the Product has been purchased from a dealer authorised by Zodiac Australia to supply it (**Authorised Dealer**). Purchase from an Authorised Dealer ensures that the product is a genuine Zodiac product, that it is the version designed for Asia Pacific conditions, and that the Purchaser has access to appropriate technical knowledge and advice.
- 2 Zodiac Australia's liability under this express warranty is limited, at its option, to the repair or replacement of the Product or the payment of the cost of having the Product repaired or replaced.
- 3 This express warranty does not apply in the following circumstances:
  - (a) if the Product has not been installed in accordance with Zodiac's installation instructions;
  - (b) if the Product has been modified other than as authorised by Zodiac Australia or if a component part has been replaced by a part that is not a genuine Zodiac product;
  - (c) if a defect results from use of the Product outside recommended operating conditions; or
  - (d) if a defect results from damage (including damage to any internal electronics) caused by a power surge or lightning strike.

Zodiac chlorinators are designed and tested in accordance with International Standard EN 61000-6-1 immunity measurements. They are designed to tolerate minor fluctuations (2000 volts) in power supply that can be reasonably expected to occur in the energy grid. They will not tolerate power surges outside these limits nor will they withstand lightning strikes.

- 4 Without limiting 3 above, products sold by Zodiac Australia are designed for use with swimming pool water balanced in accordance with Australian Standard AS3633-1989 with a pH range of 7.0 - 7.8. Maximum chlorine readings should not exceed 4ppm. Where pool water is not maintained within these parameters, Zodiac Australia will not be responsible under this express warranty for any resulting damage, including damage caused by corrosion, scaling or stress loading.
- 5 Replacement parts supplied under this express warranty are warranted to be free from defects in materials and workmanship for the remainder of the warranty period or for 12 months from the supply of the replacement, whichever is longer.
- 6 Warranty claims relating to replacement of the electrodes for LM series, C series, Duo Clear and D series chlorinators are subject to the following pro-rata pricing procedure. The Purchaser must pay for the replacement electrode a proportion of the cost equal to that proportion of the warranty period during which the original electrode functioned effectively. The warranty period for the replacement electrode is the remainder of the warranty period for the original electrode or 12 months from the supply of the replacement, whichever is longer. The Purchaser must pay full cost for any replacement electrodes after the first replacement.

## Product warranty registration

- 7 Purchasers should register their Products as soon as conveniently possible after purchase by completing a Product Warranty Registration Form and posting it to Zodiac Australia at the address shown on the Form or by registering online at [www.zodiac.com.au](http://www.zodiac.com.au).
- 8 Product registration must occur, and proof of purchase must be received by Zodiac Australia, prior to any warranty work being approved. Where applicable, a serial number, installation date and name of installer is required as part of the registration process.

### How to make a warranty claim

- 9 The Purchaser must telephone or email Zodiac Australia Customer Service and obtain a warranty ID number for the warranty claim.  
Contact details are:  
**Zodiac Group Australia Pty Ltd**  
219 Woodpark Road  
Smithfield NSW 2164  
**Customer Service**  
Telephone: 1800 688 552  
Email address: [aftersales@zodiac.com.au](mailto:aftersales@zodiac.com.au)
- 10 Zodiac Australia reserves the right to determine, in relation to each warranty claim, whether the Product should be returned to the Authorised Dealer at the address where the Purchaser purchased the Product or whether warranty service will be provided in the field, repaired at a Zodiac workshop or at the premises of an authorized Zodiac warranty agent.
- 11 If it is necessary for the Purchaser to incur freight charges in making a valid claim under this warranty, Zodiac Australia will reimburse the Purchaser for charges reasonably incurred upon proof of the charges.

## Additional guarantees, rights and remedies

### Australian Purchasers - Guarantees under the Australian Consumer Law

- 12 The benefits of this express warranty are in addition to other guarantees, rights and remedies Australian consumers have under the Australian Consumer Law.
- 13 Zodiac Australia products come with guarantees that cannot be excluded under the Australian Consumer Law. You are entitled to a replacement or refund for a major failure and for compensation for any other reasonably foreseeable loss or damage. You are also entitled to have the goods repaired or replaced if the goods fail to be of acceptable quality and the failure does not amount to a major failure.

### Purchasers in other Countries

- 14 The laws and regulations of other countries may confer on Purchasers in those countries additional rights and remedies. To the extent that they cannot be excluded or modified, Purchasers have the benefits of those rights and remedies in addition to the benefits of this express warranty. To the full extent that it is permissible to do so, those additional rights and remedies are excluded or modified so as to be consistent with Zodiac Australia's express warranty.

### INCONSISTENCY WITH WARRANTY STATEMENTS IN PRODUCT MANUALS OR OTHER DOCUMENTS ACCOMPANYING PRODUCTS

If any warranty statements in a Zodiac Australia product manual or other document are inconsistent with the above Express Warranty and Guarantees, the above overrides and replaces the inconsistent statements.





## **ZODIAC CUSTOMER SERVICE CENTRE**

Zodiac Group Australia:  
219 Woodpark Rd, Smithfield,  
NSW 2164 Australia  
Tel: 1800 688 552  
Fax: 1300 781 688  
Email: [aftersales@zodiac.com.au](mailto:aftersales@zodiac.com.au)  
[www.zodiac.com.au](http://www.zodiac.com.au)

Due to constant developments and improvements,  
specifications may change without notice.  
Improper use could affect performance and void warranty.

© Copyright Zodiac Australia Ltd 2013