



Owner's Manual



Rainbow Pool Products

PO Box 2388, Mansfield Qld 4122

Telephone STD 61-7-3849 5385

Facsimile STD 61-7-3849 5384

Email: info@rainbowpoolproducts.com.au

Web: www.rainbowpoolproducts.com.au

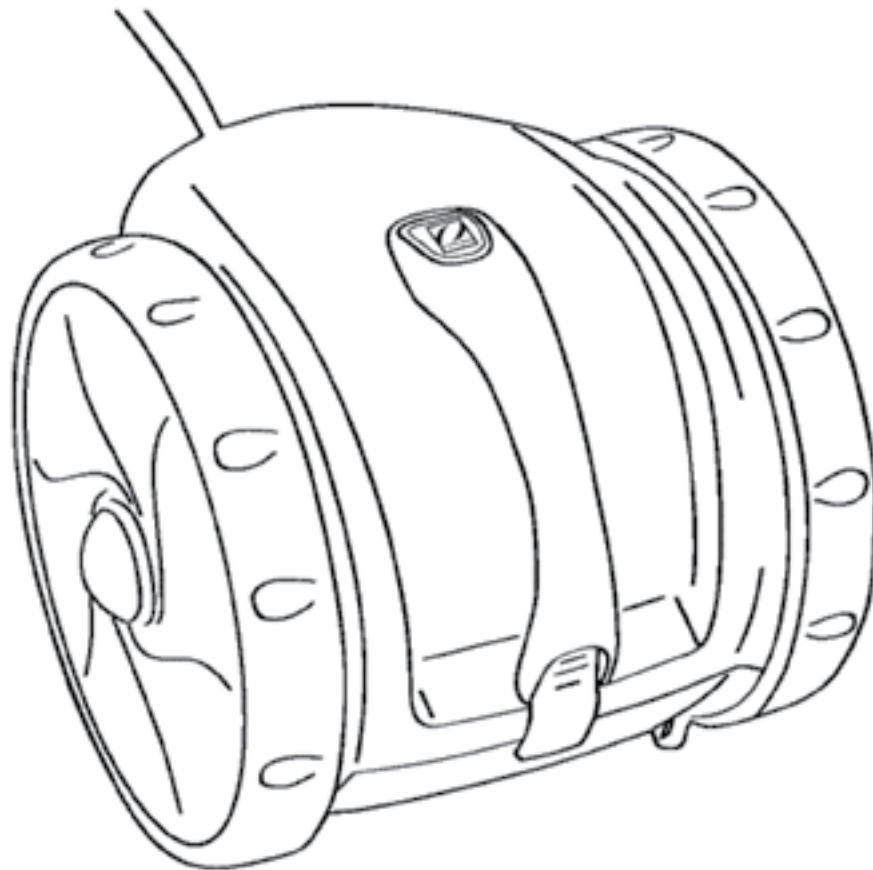

⚠ WARNING

FOR YOUR SAFETY - For anything other than the routine cleaning and maintenance described in this manual, this product must be serviced by a contractor who is licensed and qualified in pool equipment by the jurisdiction in which the product will be installed where such state or local requirements exist. In the event no such state or local requirement exists, the maintainer must be a professional with sufficient experience in pool equipment installation and maintenance so that all of the instructions in this manual can be followed exactly. Improper installation and/or operation will void the warranty.

Table of Contents

Section 1.	Important Safety Instructions	4	Section 5.	Cleaning and Maintenance	9
Section 2.	Zodiac V1 Specifications.....	6	5.1	Cleaning the Filter Canister.....	9
2.1	General Specifications	6	5.2	Replacing the Filter Canister	9
Section 3.	Assembly and Initial Usage.....	6	5.3	Cleaning and Storing the Cleaner ..	10
3.1	Unpacking	6	5.4	Replacing the Brushes	10
3.2	Attaching the Control Unit to a Wall	6	5.5	Replacing the Tyres on the Cleaner.....	11
3.3	Electrical Connection	7	Section 6.	Troubleshooting	12
Section 4.	Operation	7	6.1	General Troubleshooting.....	12
4.1	Submerging the Cleaner	7			
4.2	Operating the Cleaner.....	7			
4.3	Removing the Cleaner from Pool ...	8			

THANK YOU FOR PURCHASING THE ZODIAC V1 ROBOTIC CLEANER.

YOUR ZODIAC V1 ROBOTIC CLEANER HAS BEEN DESIGNED AND MANUFACTURED TO BE EASILY INSTALLED AND TO PROVIDE LOW MAINTENANCE OPERATION. PRIOR TO INSTALLING YOUR NEW ZODIAC V1, PLEASE DO THE FOLLOWING:

- 1) Complete and return the warranty card.
- 2) Record your purchase information on the spaces provided below.
- 3) Attach your invoice (or a copy) to this page.

Taking these steps will help ensure prompt warranty service, should it be required. If service is required, please contact your original dealer. If the original dealer does not perform warranty service, please visit www.zodiac.com.au to locate an independent service company near you. If you are unable to locate a service company, please call our Technical Support Department on 1800 688 552.

RECORD YOUR ZODIAC V1 POOL CLEANER DATA HERE:

Date of Purchase _____ Purchased From _____ Serial Number: _____
(On ID Plate Located on Bottom of Control Unit)

City _____ State _____ Post Code _____

Section 1. Important Safety Instructions

Congratulations on purchasing the Zodiac V1 robotic cleaner. Please take a moment to read through the entire manual before installing your new robotic pool cleaner. Your cleaner must be installed and operated as specified.

READ AND FOLLOW ALL INSTRUCTIONS

WARNING

Failure to comply with the following warnings can result in permanent injury, electrocution or drowning.

PREVENT ELECTRICAL SHOCK

To reduce risk of electrical shock:

- Connect unit to receptacle protected by a Ground Fault Circuit Interrupter (GFCI) or a Residual Current Device (RCD) having a rated residual operating current not exceeding 30mA.
- While the control unit is water resistant, it is not intended for any type of sustained contact with water. Therefore, it should be installed at least 3 metres from the inside wall of your swimming pool. Never submerge the control unit.
- Be sure to follow all applicable local and national electrical and installation codes.
- The cleaner is for fixed installations only and to be used in conjunction with swimming pool equipment. The cleaner is to be installed in accordance with the relevant requirements of the Australian wiring rules AS/NZS 3000. Also refer to the installation instructions relating to the swimming pool equipment for which the cleaner will be an integral part. The cleaner is to be supplied through a Residual Current Device (RCD) with a rated residual operating current of 30mA.
- Do not enter pool while the Zodiac V1 is in water.
- Do not bury cord. Locate cord so as to prevent it from being damaged by lawn mowers, hedge trimmers and other equipment.
- To reduce the risk of electrical shock, do not use the Zodiac V1 robotic cleaner or control unit if the cord is worn or damaged. Contact Zodiac Group Australia. technical support immediately for a replacement cord.
- Double insulation—For continued protection against possible electric shock, use only identical replacement parts when servicing. Do not attempt repair of the Zodiac V1 robotic cleaner, control unit, power cord, or floating cable.
- NEVER OPEN CONTROL UNIT.
- Do not use an extension cord to connect the unit to electric supply; provide a properly located outlet. The control unit should be placed near the outlet box.

PREVENT CHILD INJURY AND DROWNING

- To reduce the risk of injury, do not permit children to operate this product.
- Do not let anyone, especially small children, sit, step, lean, or climb on any equipment installed as part of your pool's operational system.

⚠ CAUTION

Failure to comply with the following warnings could cause damage to pool equipment or personal injury.

- The Zodiac V1 must be installed and operated as specified.
- This product is intended for use with permanently-installed pools. Do not use with storable pools. A permanently-installed pool is constructed in or on the ground or in a building such that it cannot be readily disassembled for storage. A storable pool is constructed so that it is capable of being readily disassembled for storage and reassembled to its original integrity.
- Turn the Zodiac V1 off before removing it from water, and do not operate out of water.
- Clean the filter canister in the Zodiac V1 after each use.
- Do not use the product in your pool if the water temperature is above 35° C or below 13° C.

⚠ CAUTION**USE OF THE ZODIAC V1 ROBOTIC CLEANER IN A VINYL LINER POOL**

Certain vinyl liner patterns are particularly susceptible to rapid surface wear of pattern removal caused by objects coming into contact with the vinyl surface, including pool brushes, pool toys, floats, fountains, chlorine dispensers, and automatic pool cleaners. Some vinyl liner patterns can be seriously scratched or abraded simply by rubbing the surface with a pool brush. Ink from the pattern can also rub off during the installation process or when it comes into contact with objects in the pool. Zodiac Group Australia, is not responsible for, and the Limited Warranty does not cover, pattern removal, abrasion or markings on vinyl liners.

Section 2. Zodiac V1 Specifications

2.1 General Specifications

The general specifications for the Zodiac V1 are as follows:

Control unit voltage:	240 VAC, 50 Hz short-circuit-proof safety isolating type	
Zodiac V1 supply voltage:	30 V DC, max.	
Installed load:	70 W max	
Cable length:	15 m	
Weight of cleaner:	6 kg	
Filtration efficiency:	200 microns	
Cycle length:	2 hrs	

The Zodiac V1 is a double-insulated product. A double-insulated electrical appliance is one which has been designed in such a way that it does not require a safety connection to ground. The basic requirement for double-insulation is that no single failure can result in dangerous voltage becoming exposed so that it might cause an electric shock and that this is achieved without relying on an earthed (grounded) metal casing. This is achieved by having two (2) layers of insulating material surrounding live parts or by using reinforced insulation.

Therefore, devices having double-insulated construction, such as the Zodiac V1, do not utilize a grounded (three-prong) cord/plug.

Section 3. Assembly and Initial Usage

3.1 Unpacking

The packaging should contain the following items (Refer to Figure 1):

- Zodiac V1 robotic cleaner
- Control unit
- Hardware and template
- Owner's Manual

Check that the unit has not been damaged during transport. If you detect damage, contact Zodiac Group Australia on 1800 688 552 before using your Zodiac V1 robotic cleaner.

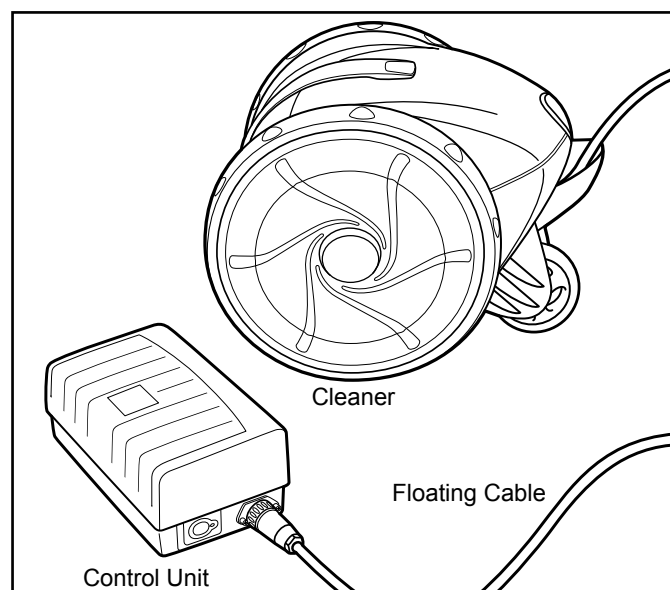

Figure 1. Zodiac V1 Components

To unpack the Zodiac V1 and its components:

1. Open the top flaps of the carton.
2. Remove the control unit from the carton.
3. Remove the floating cable and then the cleaner from the carton.

3.2 Attaching the Control Unit to a Wall

1. Place the template, provided with the unit, on the wall where you want to attach the control unit.
2. Using the appropriate drill bit, drill three (3) holes. Screw the three (3) 1/4" (6mm) screws, provided with the unit, into the holes and place the control unit onto the screws. Refer to Figure 2.

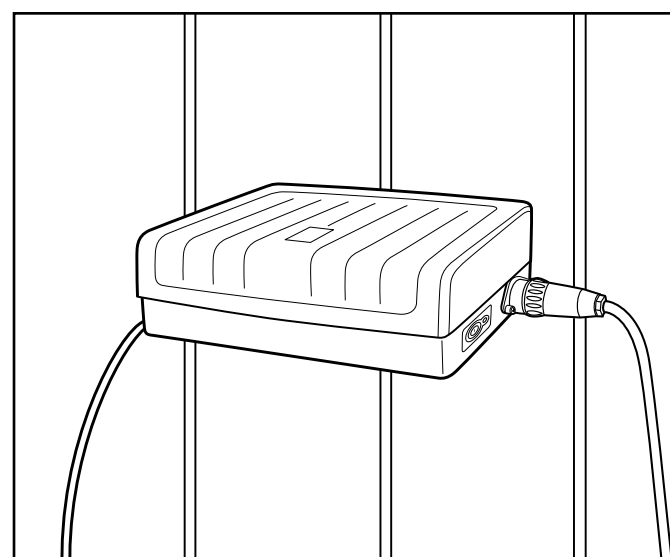

Figure 2. Position Control Unit on the Wall

SAVE THESE INSTRUCTIONS

3.3 Electrical Connection

⚠ WARNING

Failure to comply with the following warnings can result in permanent injury, electric shock or drowning.

PREVENT ELECTRICAL SHOCK

- Keep the control unit at least 3 metres from the edge of the pool. Never submerge the control unit.
- Only connect the control unit to a receptacle protected by a Residual Current Device (RCD), having a rated residual operating current not exceeding 30mA. Contact a certified electrician if you cannot verify that the receptacle is protected by a RCD.
- Do not use an extension cord to connect the control unit.
- Do not allow anyone to swim while the Zodiac V1 robotic cleaner is in the pool.

For your safety and to obtain the best possible performance from your Zodiac V1, connect the cleaner's floating cable to the cleaner's control unit by twisting the threaded connector until it is snug. Do not overtighten. Refer to Figure 3.

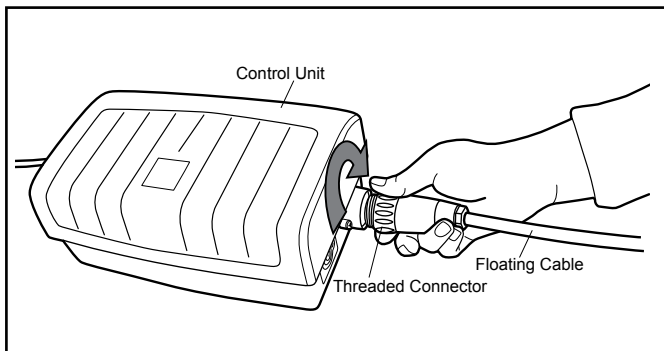

Figure 3. Electrical Connection

The green indicator light on the control unit will illuminate for a short period to indicate that the cycle is ready to start. Do not try to start a cycle until the indicator is illuminated.

IMPORTANT

- The Zodiac V1 control unit is equipped with an automatic shut off feature to prevent overheating if operated in direct sunlight for an extended period of time.

⚠ WARNING

The Zodiac V1 control unit is water-resistant, not waterproof. In order to prevent the risk of electric shock which could result in serious injury or death, never submerge the control unit.

Section 4. Operation

4.1 Submerging the Cleaner

1. While holding the cleaner by the handle, submerge the cleaner in the pool and remove any air trapped inside by keeping the unit vertical. Make sure that the cleaner sinks to the bottom of the pool. Refer to Figure 4.

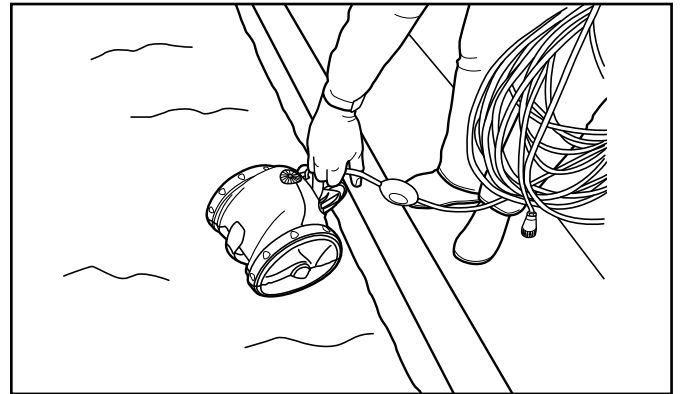

Figure 4. Submerge the Cleaner Vertically

2. Spread the floating cable out over the pool, ensuring there are no kinks or bends in the cable. Refer to Figure 5.

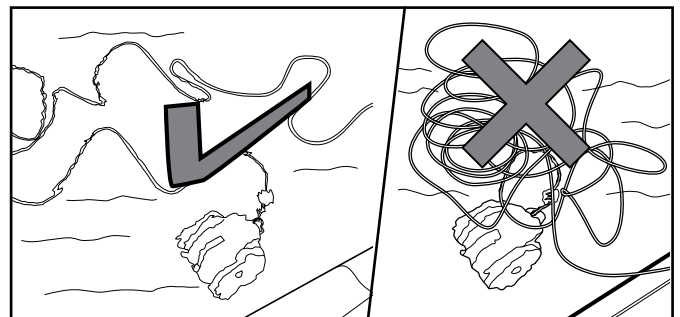

Figure 5. Spread Floating Cable Over the Pool

4.2 Operating the Cleaner

1. To start your Zodiac V1 robotic cleaner, press the ON/OFF button. Refer to Figure 6. The green indicator light will illuminate briefly and the cleaner will start up after just a few seconds.

NOTE: The cleaner will clean the floor and lower portion of the pool wall. The cleaner will not reach the water line.

2. If you wish to stop the cleaner during the cleaning cycle, press the ON/OFF and ensure that the green LED light goes off. Refer to Figure 6.
3. At the end of the cycle, the cleaner needs a cool down period of 15 minutes to prevent damage to the seals. During this period, the green indicator light stays ON permanently.

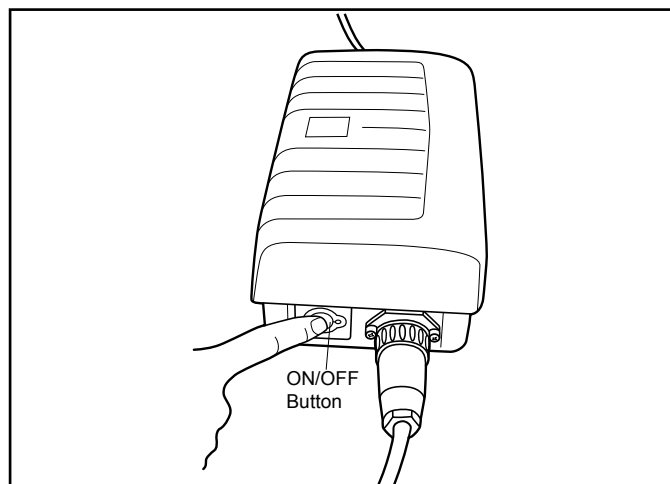

Figure 6. Start the Cleaner.

- After the cool down period is complete, the green indicator will turn off. The unit can be removed from the pool.

NOTE The Zodiac V1 includes a safety feature that automatically stops the cleaner if it is powered ON when it is not submerged in the water. For pools equipped with a beach area, this safety feature allows the cleaner to reverse, and go back into the pool.

4.3 Removing the Cleaner from Pool

- Remove the Zodiac V1 from the pool after the cleaning cycle is completed.

⚠ CAUTION

To prevent damage to the cleaner, never lift the Zodiac V1 robotic cleaner out of the pool using the floating cable.

Remove the Zodiac V1 from pool when super chlorinating.

Do not handle cleaner while it is in operation.

- Never lift the Zodiac V1 out of the pool by the floating cable. Always use the handle to remove it from the pool. Drain the remaining water from the cleaner by keeping the cleaner in a vertical position. Refer to Figures 7 and 8.
- Disconnect the control unit cable from the electrical outlet.
- Disconnect the cable from the control unit.
- At the end of each cycle, coil the cable starting at the cleaner and go toward the connection point at control unit. Remove coils or twists along the way.
- Store cleaner out of direct sunlight.

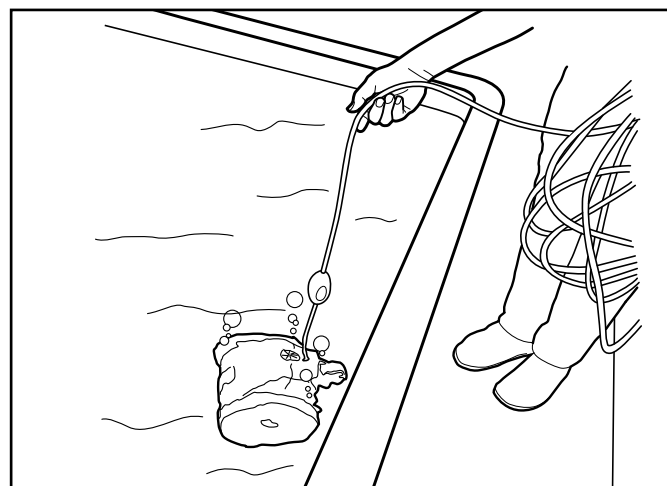

Figure 7. Remove Cleaner From Pool

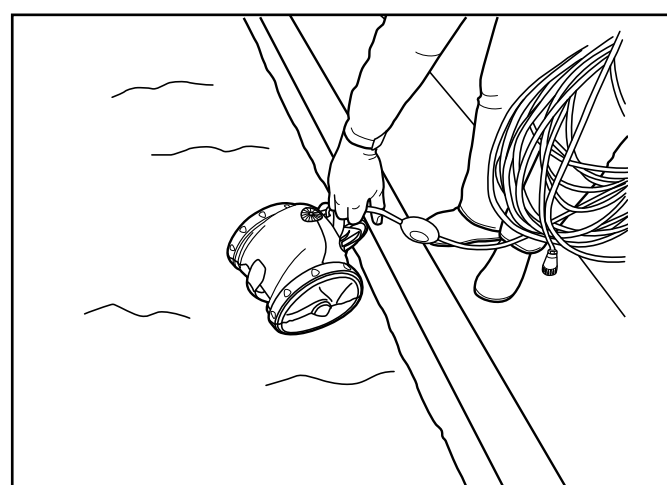

Figure 8. Keep Cleaner Vertical to Drain Water

IMPORTANT

- Use your Zodiac V1 robotic cleaner as often as needed to keep your pool clean.
- Clean the filter canister after each cleaning cycle.
- Do not leave your cleaner in the pool on a permanent basis.
- At the end of each cycle, remove the cleaner from the pool. Start at the cleaner head and untangle any coils in the hose before storing the cleaner.

Section 5. Cleaning and Maintenance

⚠ WARNING

To avoid electric shock and other hazards which could result in permanent injury or death, disconnect (unplug) the cleaner from the electrical outlet before performing any cleaning and maintenance.

5.1 Cleaning the Filter Canister

The filter canister should be cleaned at the end of each cycle.

1. Ensure that the control unit cable has been disconnected from the electrical outlet.
2. Set the unit on its wheels.
3. Push the cover latch and lift the cover. Refer to Figure 9.

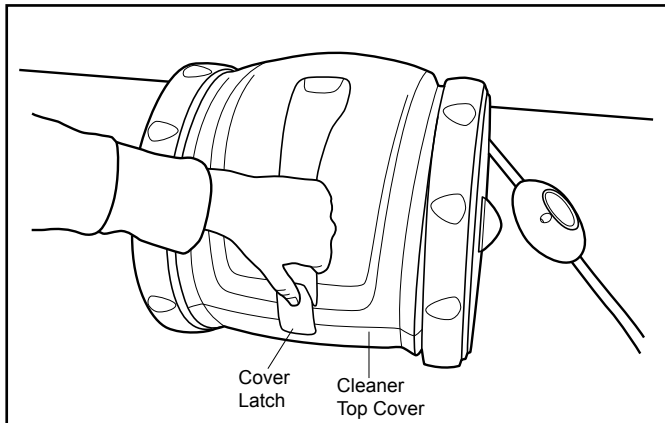

Figure 9. Open Cover of the Cleaner

4. Remove the filter assembly from the body, as shown in Figure 10.

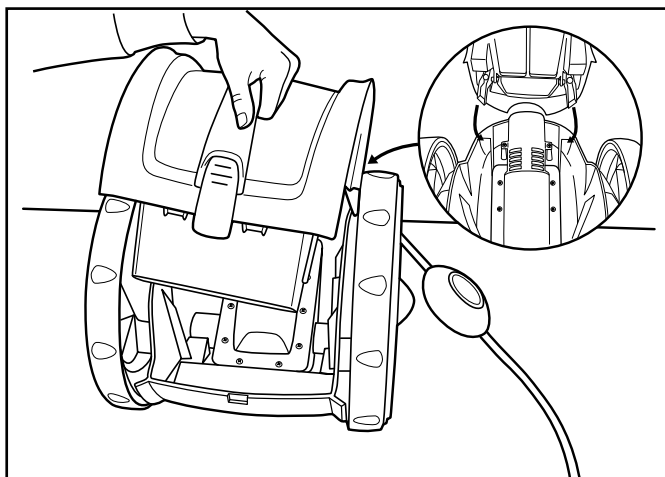

Figure 10. Remove the Filter Canister/Cover Assembly

5. Press the canister clip with your finger to separate the filter canister from the top cover, as shown in Figure 11.
6. Wash the filter canister with water using a hose.

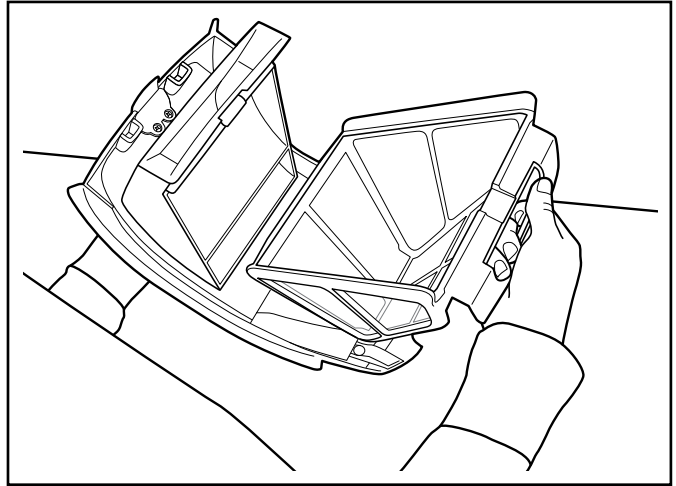

Figure 11. Remove Filter Canister from Cover

5.2 Replacing the Filter Canister

1. Position the filter canister hooks on the top cover receiving pins, as shown in Figure 12.

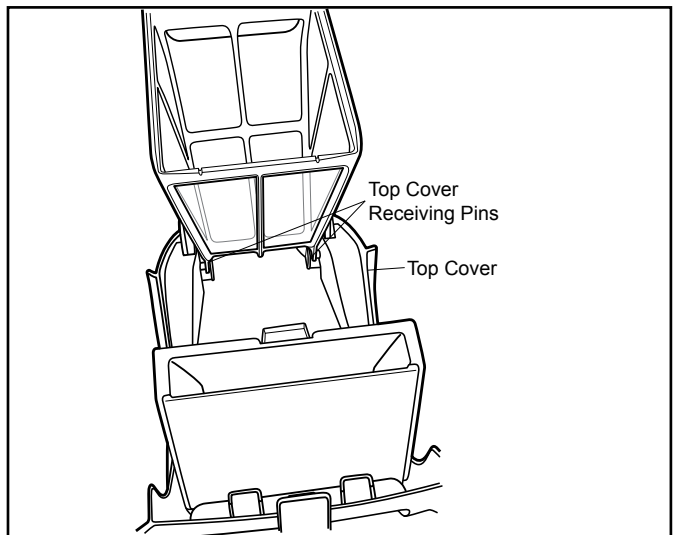

Figure 12. Engaging the Filter Canister Hooks on Top Cover

2. Rotate the filter canister and lock it in place using the front clip. Refer to Figure 13. When the filter canister is installed properly on the top cover, it will be firmly attached.
3. Locate the top cover hinges under the body shoulders, as shown in Figure 14.
4. Lower the cover and allow the cover latch to lock the top cover in place. Refer to Figure 9.

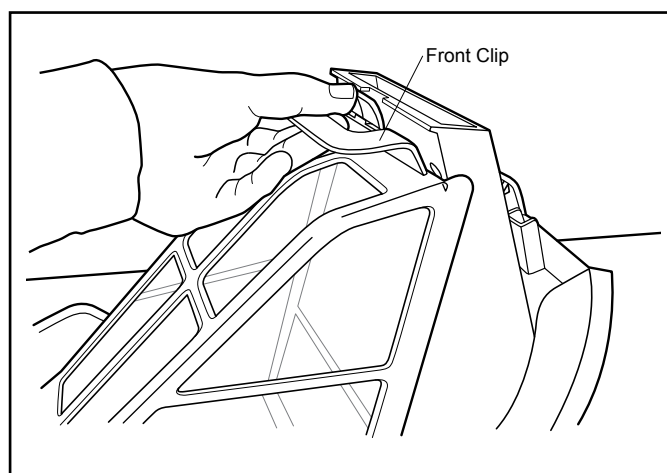

Figure 13. Position and Lock the Filter Canister in Place

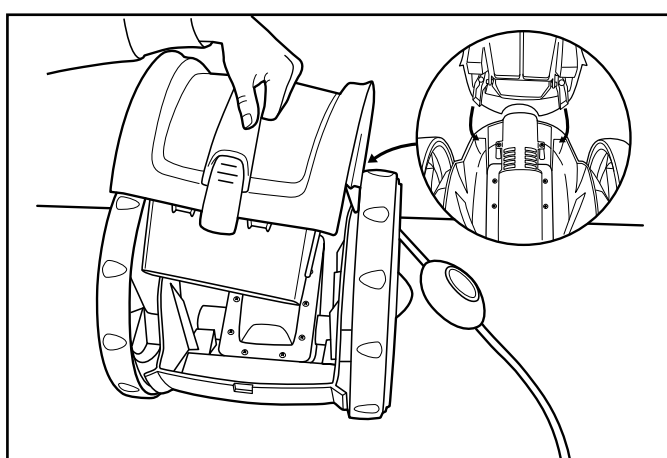

Figure 14. Install the Cover

5.3 Cleaning and Storing the Cleaner

The cleaner must be cleaned regularly using slightly soapy clean water, do not use solvents. Rinse the cleaner generously using clean water. Store the cleaner in a cool dry place.

NOTE: The cleaner cable must be disconnected from the control unit before removing the cleaner from the pool.

5.4 Replacing the Brushes

The cleaner is fitted with a PVC brush. To maintain cleaner performance at its best, you will need to replace the brushes when they are worn.

1. Place the cleaner upside-down so that you can access the brush. Refer to Figure 15.
2. Push on one of the arms of the brush to remove its shaft from the bushing, as shown in Figure 15.
3. Lift the brush and then remove it from the cleaner. Refer to Figure 16.

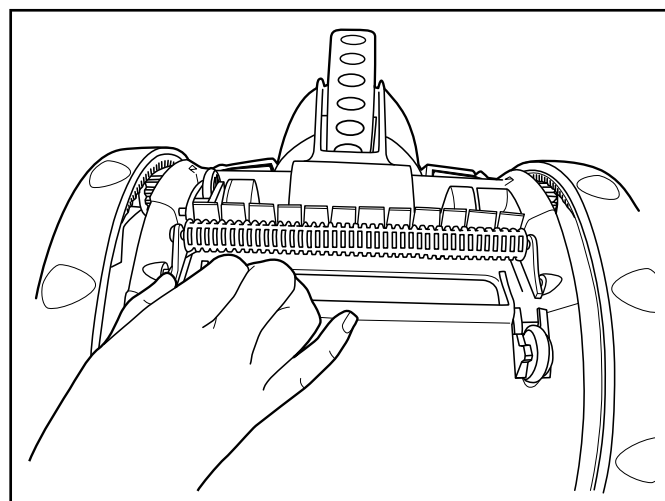

Figure 15. Push Brush Arm

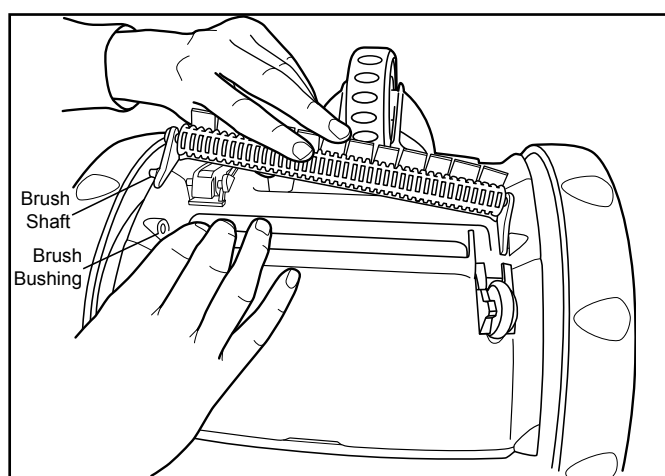

Figure 16. Remove and Replace the Brush From the Cleaner

4. Install the new brush shaft in its bushing. Refer to Figure 16.
5. Install the second shaft (on the other side) of the new brush in its bushing. Refer to Figure 16.

5.5 Replacing the Tyres on the Cleaner

1. Using your fingers, pull on the inside of the old tyre to remove the tyre lip from the wheel. See Figure 17.

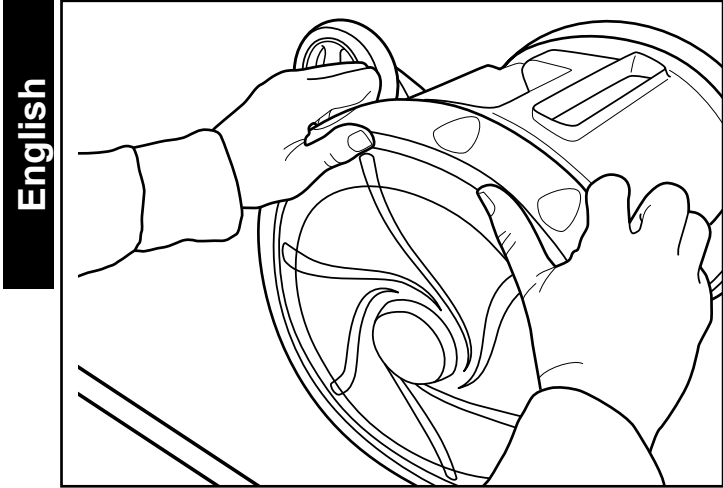

Figure 17. Pull on Inside of Old Tyre

2. Remove the old tyre as shown in Figure 18.

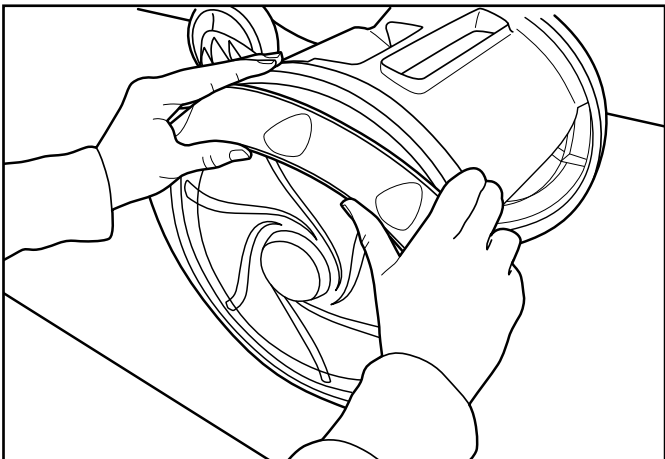

Figure 18. Remove the Old Tyre From the Cleaner

3. To replace the tyre, position the new tyre on the wheel making sure to orient the tyre so that the tyre groove pattern is on the outer side of the wheel. See Figure 19.

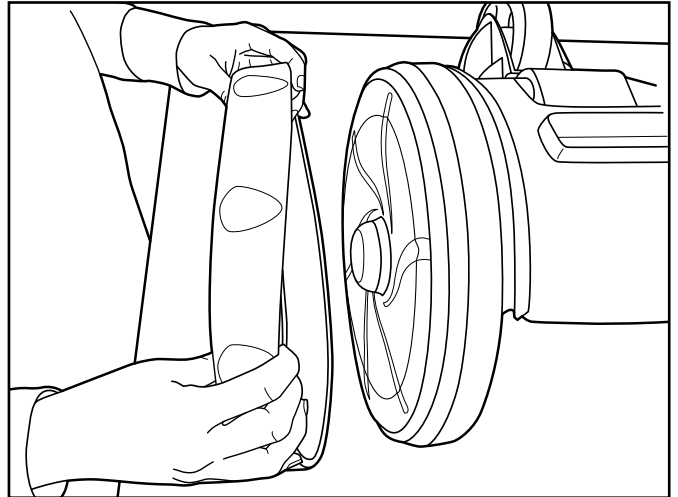

Figure 19. Tyre Replacement Orientation

4. Push one side of the tyre on to the wheel and fit the tyre onto the wheel as shown in Figure 20.

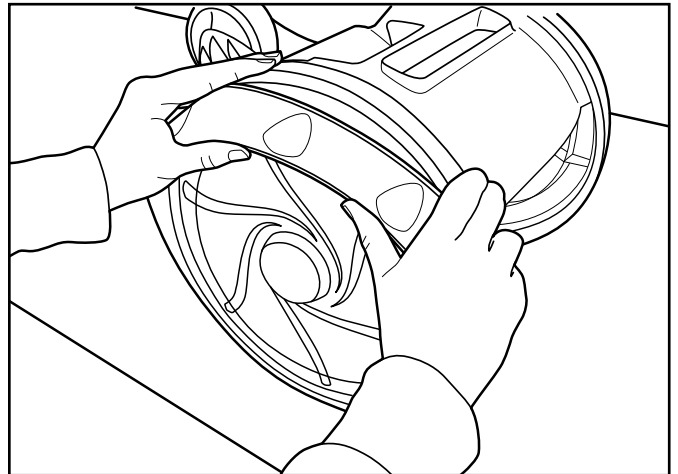

Figure 20. Push Tyre onto the Wheel

5. Work the tyre around and onto the wheel. Refer to Figure 21.

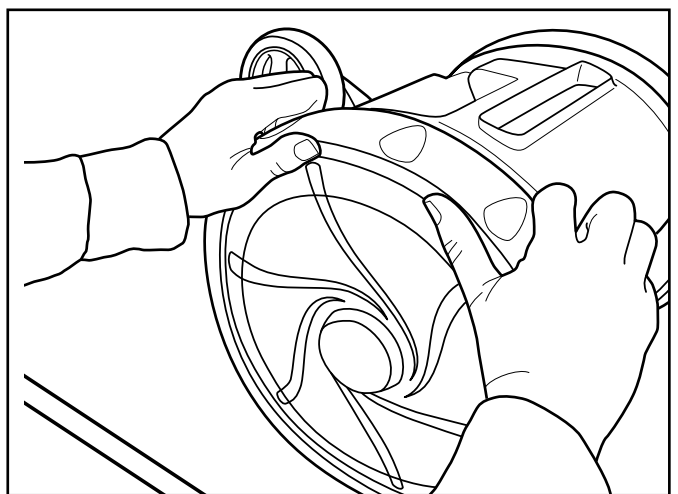
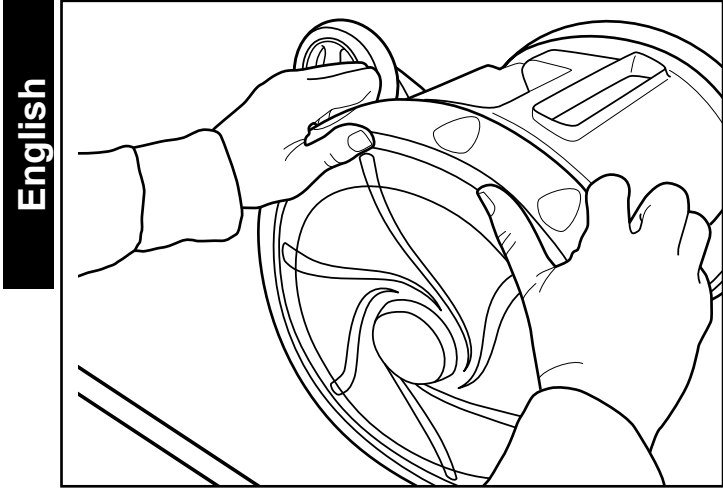

Figure 21. Push the Tyre Into Place



Section 6. Troubleshooting

6.1 General Troubleshooting

Table 1 lists some of the more common symptoms, causes and solutions encountered when using the cleaner.

⚠ WARNING		
In order to prevent the risk of electric shock which could result in serious injury or death, DO NOT open the control unit.		
Symptom	Cause	Solution
The cleaner does not move and the green indicator light does not illuminate.	Unit is OFF.	Make sure the ON/OFF button is turned ON.
	Cleaner is not supplied with electricity.	<ol style="list-style-type: none"> 1. The electrical outlet the control unit is connected to is not supplying electrical power. 2. Plug main power cord into another electrical outlet that is powered and ensure the green light flashes once. 3. If the green indicator does not illuminate, contact your local pool shop.
The green indicator light flashes after you press the ON/OFF button.	Control unit needs to be reset/not properly connected.	Submerge the cleaner following the procedure in Section 4.1, "Submerging the Cleaner". <ol style="list-style-type: none"> 1. To reset the supply: <ol style="list-style-type: none"> a. Unplug the main power cord from the electrical receptacle. b. Disconnect the floating cable connector from the control unit and then reconnect it following the procedures in Section 3.3, "Electrical Connection". c. Plug the main cord in the electrical receptacle and check if the green indicator light illuminates. d. Press the ON/OFF button. If the green indicator does not illuminate or flashes, contact your local Zodiac service representative.
The cleaner does not suck the debris.	The filter is full or dirty.	Clean the filter canister following the procedure Section 5.1, "Cleaning the Filter Canister".
	The impeller is clogged or damaged.	Make a visual check of the impeller. If the impeller is clogged, unplug the main power cord from electrical receptacle then, remove debris. If the impeller is damaged contact your local Zodiac service representative.
The cleaner does not stay firmly on the pool bottom.	There is air in the appliance casing.	Submerge the cleaner following the procedure in Section 4.1, "Submerging the Cleaner".
	The impeller is clogged or damaged.	Make a visual check of the impeller. If the impeller is clogged, unplug the main power cord from electrical receptacle then, remove debris. If the impeller is damaged contact your local Zodiac service representative.
The cleaner's ability to climb the pool sides is reduced. NOTE: The cleaner is not designed to climb up to the waterline.	The filter is full or dirty.	Clean the filter canister following the procedure Section 5.1, "Cleaning the Filter Canister".
	Tyres are worn.	Replace the tyres following the procedure in Section 5.5, "Replacing the Tyres on the Cleaner."
	Sides of pool are slippery or slimy. Although the water seems clear, microscopic algae, invisible to the human eye, are present in the pool. As a result the pool sides become slippery and prevent the cleaner from climbing.	Ensure that your pool's chemicals are balanced. If the chemicals are balanced, contact your local Zodiac service representative.
The cleaner seems to be performing less efficiently.	The brushes have become worn.	Replace the brushes following the procedure in Section 5.4, "Replacing the Brushes".
	Filter canister is full or dirty.	Clean the filter canister following the procedure in Section 5.1, "Cleaning the Filter Canister".
	Floating cable is excessively coiled or kinked.	Make sure the floating cable is spread out over the pool. Lay out the floating cable in a straight line in the sun for a few hours to remove the kinks. Refer to 4.3, "Removing the Cleaner from Pool", for proper cable handling.

Zodiac Australia - Express Warranty and Guarantees

Express Warranty

Zodiac Group Australia Pty Ltd (**Zodiac Australia**) warrants that the Zodiac V1 robotic cleaner will be free from defects in materials and workmanship for the period of 2 years from date of purchase. Normal replacement items such as tyres and the filter canister which have been worn out by use or improper installation are not covered by this warranty.

Conditions

- 1 This express warranty only applies if the Product has been purchased from a dealer authorised by Zodiac Australia to supply it (**Authorised Dealer**).

Purchase from an Authorised Dealer ensures that the product is a genuine Zodiac product, that it is the version designed for Asia Pacific conditions, and that the Purchaser has access to appropriate technical knowledge and advice.

- 2 Zodiac Australia's liability under this express warranty is limited, at its option, to the repair or replacement of the Product or the payment of the cost of having the Product repaired or replaced.
- 3 This express warranty does not apply in the following circumstances:
 - (a) if the Product has not been installed in accordance with Zodiac's installation instructions;
 - (b) if the Product has been modified other than as authorised by Zodiac Australia or if a component part has been replaced by a part that is not a genuine Zodiac product;
 - (c) if a defect results from use of the Product outside recommended operating conditions; or
 - (d) if a defect results from damage (including damage to any internal electronics) caused by a power surge or lightning strike.

Zodiac chlorinators are designed and tested in accordance with International Standard EN 61000-6-1 immunity measurements. They are designed to tolerate minor fluctuations (2000 volts) in power supply that can be reasonably expected to occur in the energy grid. They will not tolerate power surges outside these limits nor will they withstand lightning strikes.

- 4 Without limiting 3 above, products sold by Zodiac Australia are designed for use with swimming pool water balanced in accordance with Australian Standard AS3633-1989 with a pH range of 7.0 - 7.8. Maximum chlorine readings should not exceed 4ppm. Where pool water is not maintained within these parameters, Zodiac Australia will not be responsible under this express warranty for any resulting damage, including damage caused by corrosion, scaling or stress loading.
- 5 Replacement parts supplied under this express warranty are warranted to be free from defects in materials and workmanship for the remainder of the warranty period or for 12 months from the supply of the replacement, whichever is longer.
- 6 Warranty claims relating to replacement of the electrodes for LM series, C series, Duo Clear and D series chlorinators are subject to the following pro-rata pricing procedure. The Purchaser must pay for the replacement electrode a proportion of the cost equal to that proportion of the warranty period during which the original electrode functioned effectively. The warranty period for the replacement electrode is the remainder of the warranty period for the original electrode or 12 months from the supply of the replacement, whichever is longer. The Purchaser must pay full cost for any replacement electrodes after the first replacement.

Product warranty registration

- 7 Purchasers should register their Products as soon as conveniently possible after purchase by completing a Product Warranty Registration Form and posting it to Zodiac Australia at the address shown on the Form or by registering online at www.zodiac.com.au.
- 8 Product registration must occur, and proof of purchase must be received by Zodiac Australia, prior to any warranty work being approved. Where applicable, a serial number, installation date and name of installer is required as part of the registration process.

How to make a warranty claim

- 9 The Purchaser must telephone or email Zodiac Australia Customer Service and obtain a warranty ID number for the warranty claim.

Contact details are:

Zodiac Group Australia Pty Ltd

219 Woodpark Road
Smithfield NSW 2164

Customer Service

Telephone: 1800 688 552

Email address: apac.aftersales@zmp.zodiac.com

- 10 Zodiac Australia reserves the right to determine, in relation to each warranty claim, whether the Product should be returned to the Authorised Dealer at the address where the Purchaser purchased the Product or whether warranty service will be provided in the field, repaired at a Zodiac workshop or at the premises of an authorized Zodiac warranty agent.
- 11 If it is necessary for the Purchaser to incur freight charges in making a valid claim under this warranty, Zodiac Australia will reimburse the Purchaser for charges reasonably incurred upon proof of the charges.

Additional guarantees, rights and remedies

Australian Purchasers - Guarantees under the Australian Consumer Law

- 12 The benefits of this express warranty are in addition to other guarantees, rights and remedies Australian consumers have under the Australian Consumer Law.
- 13 Zodiac Australia products come with guarantees that cannot be excluded under the Australian Consumer Law. You are entitled to a replacement or refund for a major failure and for compensation for any other reasonably foreseeable loss or damage. You are also entitled to have the goods repaired or replaced if the goods fail to be of acceptable quality and the failure does not amount to a major failure.

Purchasers in other Countries

- 14 The laws and regulations of other countries may confer on Purchasers in those countries additional rights and remedies. To the extent that they cannot be excluded or modified, Purchasers have the benefits of those rights and remedies in addition to the benefits of this express warranty. To the full extent that it is permissible to do so, those additional rights and remedies are excluded or modified so as to be consistent with Zodiac Australia's express warranty.

INCONSISTENCY WITH WARRANTY STATEMENTS IN PRODUCT MANUALS OR OTHER DOCUMENTS ACCOMPANYING PRODUCTS

If any warranty statements in a Zodiac Australia product manual or other document are inconsistent with the above Express Warranty and Guarantees, the above overrides and replaces the inconsistent statements.