

Drenox Models



Rainbow Pool Products

PO Box 2388, Mansfield Qld 4122

Telephone STD 61-7-3849 5385

Facsimile STD 61-7-3849 5384

Email: info@rainbowpoolproducts.com.au

Web: www.rainbowpoolproducts.com.au

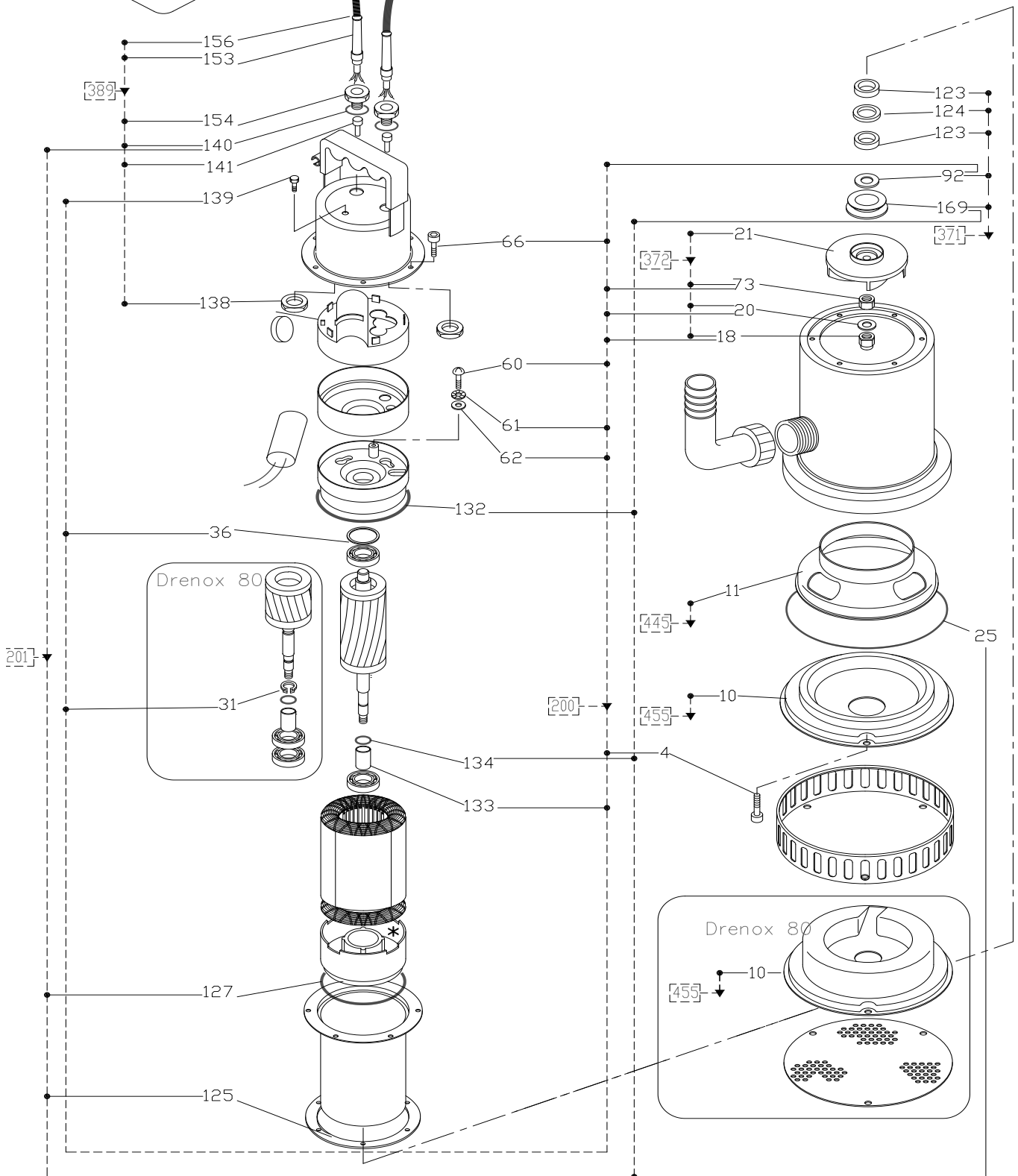

PARTS LIST TABLE

Model	DRENOX 80/7	DRENOX 250/10
Part number	P1031020	P1031400

KIT REF.	COMPONENT REFERENCE NO.	REF NO.	COMPONENT DESCRIPTION	DRENOX 80/7		DRENOX 250/10	
201	GASKET KIT	140	O-RING (CORDING CLAMP)	ZBR36770	2PC	ZBR36770	2PC
		132	O-RING (MOTOR BODY)		1PC		1PC
		125	GASKET (COVER)		1PC		1PC
		169	SAND PROTECTION		1PC		1PC
		134	O-RING (CERAMIC BUSHING)		1PC		1PC
		127	O-RING (LOWER BEARING FLANGE)		1PC		1PC
		25	O-RING (PUMP BODY)		1PC		1PC
371	MECHANICAL SEAL KIT	123	RING SEAL	ZBR36800	2PC	ZBR36800	2PC
		169	SAND PROTECTION		2PC		2PC
		92	WASHER		2PC		2PC
		124	SPACER (SEAL RING)		1PC		1PC
372	HYDRAULIC KIT	21	IMPELLER	ZBR36810	1PC	ZBR36830	1PC
		20	WASHER (IMPELLER)		1PC		1PC
		73	NUT		1PC		1PC
		18	NUT (SELF LOCKING)		1PC		1PC
389	FLOAT SWITCH	156	FLOAT SWITCH	ZBR20450	1PC	ZBR20450	1PC
		153	GROMMET (CABLE 9MM DIA)		1PC		1PC
		154	CORDING CLAMP		1PC		1PC
		140	O-RING (CORDING CLAMP)		1PC		1PC
		141	CONNECTOR 2.5SQMM		1PC		1PC
		138	NUT (CORDING CLAMP LOCKING)		1PC		1PC
445	CONVEYOR KIT	11	DIFFUSER (DISCHARGE)	ZBR36900	1PC	ZBR36900	1PC
455	KIT BASE	10	DIFFUSER (SUCTION)	ZBR36910	1PC	ZBR36920	1PC

Dimensions

DRENOX 80/7

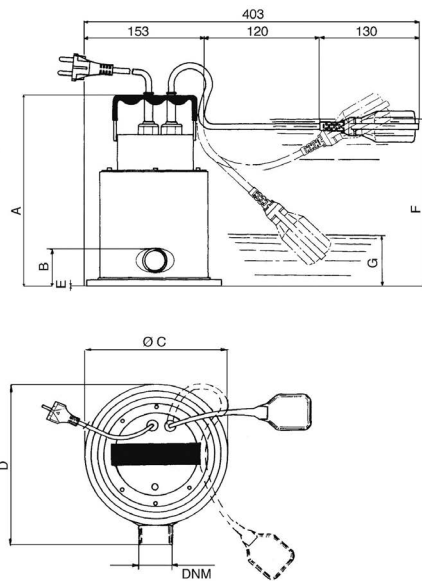

DRENOX 160/8 - 250/10 - 350/12

